



Aircraft Covering Process

# PROCEDURE MANUAL



**By Jon Goldenbaum**



Star Gloss  
Procedure Manual  
STC SA4503NM  
Instructions for  
Continued Airworthiness  
Original Issue May 2010



# Revision Page

This is the May 2010 edition of this manual, the initial edition.

This manual is printed and permanently bound with 114 pages. Pages are not replaceable; rather, the whole manual is revised and reprinted when required.

Major sections are:

Chapter 1 – Getting Ready: pages 1-6  
Chapter 2 – Airframe Preparation: pages 7-10  
Chapter 3 – Tune Up Your Iron: pages 11-12  
Chapter 4 – Attaching the Fabric: pages 13-14  
Chapter 5 – Let's Do a Wing: pages 15-46  
Chapter 6 – Control Surfaces & Fuselage: pages 47-52  
Chapter 7 – Spraying Silver Urethane Fabric Primer: pages 53-56  
Chapter 8 – Spraying Ranthane Topcoat: pages 57-60  
Appendix A: Envelopes & Sewing: pages 61-64  
Appendix B: Concave-bottom Wings: pages 65-66  
Appendix C: Covering Plywood Surfaces: pages 67-68  
Appendix D: Airworthiness Limitations: pages 69-70  
Appendix E: Inspecting Fabric and Coatings: pages 71-72  
Appendix F: Star Gloss Repairs: pages 73-78  
Appendix G: Product Profiles: pages 79-88  
Charts, Tables, Forms: pages 89-114

# Product Descriptions

Appendix G, Product Profiles, has a complete description of all PMA'd fabrics, tapes, and chemicals called for in the installation of this covering system.

Mixing instructions, shelf lives, and specific application instructions are covered in detail for each product.

We recommend that you refer to Appendix G, Product Profiles, to answer specific questions about products as you follow the installation instructions in the front text of the manual.

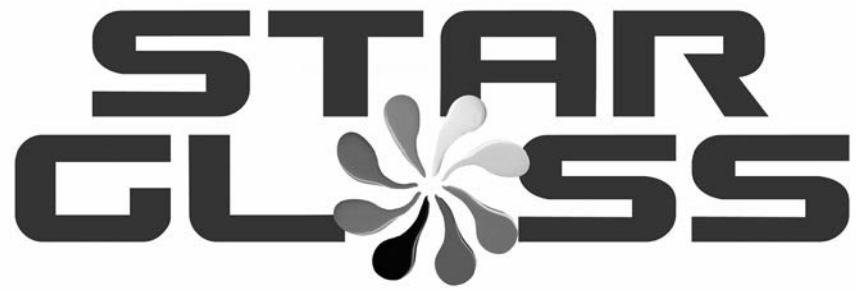

Aircraft Covering Process

# PROCEDURE MANUAL

**By Jon Goldenbaum**





**Concept, design, and execution by**



FlatHat@comcast.net

Copyright © 2010  
Consolidated Aircraft Coatings  
Ceconite Division  
PO Box 3129, Riverside, CA 92519-3129  
951-684-4280 • Fax 951-684-0518  
All rights reserved.

No part of this publication may be reproduced  
in any form or by any means without permission.

# C O N T E N T S

<b>Chapter 1 – Getting Ready . . . . .</b>	<b>1</b>	<b>Chapter 5 – Let's Do a Wing! . . . . .</b>	<b>15</b>
The Goal of This Manual . . . . .	1	Basically, the steps are... . . . . .	15
Two Different Systems Using Ceconite Fabrics . . .	1	Handy Sawhorses . . . . .	15
STAR GLOSS - What Is It? . . . . .	1	Covering the Wing, Step by Step . . . . .	15
The Ceconite STC Number . . . . .	1	First, the Leading Edge . . . . .	16
Certified Aircraft - The Basic Rules: . . . . .	1	How Tight Should That Fabric Be? . . . . .	17
Amateur-built Aircraft . . . . .	2	Uh Oh... Protrusions! . . . . .	17
The Fabrics to Use With STAR GLOSS . . . . .	2	Next, the Trailing Edge . . . . .	17
Health Issues . . . . .	3	Now for the Butt Rib . . . . .	18
Protect Your Skin! . . . . .	3	Aileron and Flap Recesses . . . . .	18
Protect Your Lungs and Body! . . . . .	3	The Curved Wingtip Bows . . . . .	19
Protect Your Eyes! . . . . .	3	Now For the Top Fabric . . . . .	20
Fire Prevention . . . . .	3	Before You Start Ironing... . . . .	21
A Practical Work Area . . . . .	4	Heat Tightening . . . . .	21
Atmospherics and Spraying . . . . .	4	Make Sure the Iron is Set to 250° . . . . .	21
Tools You'll Need . . . . .	5	Now Set the Iron is to 350° . . . . .	21
Fuselage Holding and Turning Jig . . . . .	5	Protrusions . . . . .	22
About Spray Guns . . . . .	6	Brushed Coat of Gray Sealer . . . . .	22
Materials You'll Need . . . . .	6	Rib Lacing . . . . .	23
		How Far Between the Laces? . . . . .	24
		Using the Chart . . . . .	24
		Marking Rib Lace Locations . . . . .	25
		The Magic Template . . . . .	26
		Reinforcing Tape . . . . .	27
		Let's Tie Some Knots! . . . . .	28
		Rib Lacing Cords . . . . .	28
		Only three knots are approved with	
		the Ceconite STC: . . . . .	28
		Before You Begin Any Knot . . . . .	29
		How to Tie a Starter Knot . . . . .	30
		How to Tie a Hidden Modified Seine Knot . . . . .	31
		What If You Can't Get Through the	
		Entire Wing to Rib Lace Normally? . . . . .	34
		Other Mechanical Attachments: . . . . .	35
		Pop Rivets . . . . .	35
		PK Screws . . . . .	35
		Fabric Clips . . . . .	35
		Finishing Up . . . . .	35
		Inspection Hole Reinforcements . . . . .	36
		Finishing Tapes and Gussets . . . . .	37
		Kinds of Tapes . . . . .	37
		Let's Tape! . . . . .	38
		Tapes are applied in this order: . . . . .	38
		Fabric Gussets . . . . .	38
		Chord-wise Tapes . . . . .	39
<b>Chapter 2 – Airframe Preparation . . . . .</b>	<b>7</b>		
Take Your Time . . . . .	7		
The Right Stuff: Epoxy . . . . .	7		
Wood Surfaces . . . . .	7		
Steel Tubing . . . . .	7		
Fiberglass . . . . .	8		
Aluminum . . . . .	8		
Old Aluminum . . . . .	8		
New Aluminum . . . . .	8		
Dealing With Dents and Imperfections . . . . .	8		
Replace Badly Damaged Areas . . . . .	8		
Fill With Poly-Fiber's SuperFil . . . . .	9		
Inter-rib Bracing . . . . .	9		
Anti-chafe Tape . . . . .	9		
<b>Chapter 3 – Tune Up Your Iron! . . . . .</b>	<b>11</b>		
Heat Guns? No! . . . . .	11		
The Right Iron . . . . .	11		
Why Calibrating Your Iron is So Important . . . . .	11		
How to Calibrate Your Iron Correctly . . . . .	12		
<b>Chapter 4 – Attaching the Fabric . . . . .</b>	<b>13</b>		
Cemented Seams . . . . .	13		
Approved Cements . . . . .	13		
The Cementing Process . . . . .	14		

One-piece Rib Tape	39
Two-piece Rib Tape	40
Span-wise Tapes	41
Bias Tapes	42
Different Surfaces	43
Aircraft with Big-engine Modifications	43
Drain Grommets	43
Drain grommets come in three types:	44
Heat Smoothing	44
Imperfections You Should Fix	44
Some Other Tricks	45

**Chapter 6 – Control Surfaces & Fuselage . . .47**

Ailerons	47
Tailfeathers	47
Let's Take It Step by Step	47
Fuselage	48
Option One: Blanket Method	49
Sometimes You Have to Sew	50
Option Two: Buy a Fuselage Envelope, or Make Your Own	51
Final Steps!	52

**Chapter 7 – Spraying Silver Urethane**

**Fabric Primer . . . . . 53**

What Spray Rig Do I Use?	53
Here's an Overview of the	
Basic Spraying Steps	53
What's a Cross Coat?	53
The Biggie: Heat Smoothing With an Iron BEFORE You Spray Silver Urethane Fabric Primer.	53
Spraying	54
Mixing Silver Primer	54
Cross Coat One	54
Cross Coat Two	54
Sanding	55

**Chapter 8 – Spraying Ranthane Topcoat 57**

Step One: Prep the Silver Urethane Fabric Primer or Epoxy-primed Metal Surface	57
Step Two: Mix, Catalyze, Thin, and Filter the Paint	58
Step Three: Test Spray	58
Step Four: Paint Your Airplane.	58
Step Five: Trim Painting	59
Flattening	59
Fixing Problems	59

**Appendix A: Envelopes and Sewing . . . .61**

Envelopes	61
To Install an Envelope:	61
Envelope Pros and Cons	61
Sewing	62
Hand-sewn Seams	62
Machine-sewn Seams	62
Make Your Own Envelope!	63

**Appendix B: Concave-bottom Wings . . . .65**

Follow These Steps	65
--------------------	----

**Appendix C: Covering Plywood Surfaces 67**

Prepare the Surface	67
Varnish	67
Pre-coat With Gray Sealer	67
Apply Fabric	67
Heat Shrink	67
Gray Sealer	67
Tape and Spray Silver Urethane Fabric Primer	67

**Appendix D: Airworthiness Limitations . .69**

**Appendix E: Inspecting Fabric & Coatings .71**

Inspection Procedures:	71
The Problem Scenarios	71
The "Hang It on the Wall" Test	72
If the fabric breaks...	72

**Appendix F: Star Gloss Repairs . . . . .73**

Repairs Are Easy in the Star Gloss System	73
The Rules Are Simple	73
Let's look at a simple puncture repair using a one-inch overlap.	73
Large Repairs - Over 18 Inches	77
Here are the steps:	77

**Appendix G: Product Profiles . . . . .79**

<b>The Ceconite STC</b>	<b>89</b>
<b>The Ceconite PMA</b>	<b>91</b>
<b>The Ceconite/Star Gloss Installation Report</b>	<b>93</b>
<b>The Ceconite Approved Model List</b>	<b>95</b>
<b>Star Gloss Covering Material Estimates</b>	<b>109</b>



# A Better Manual

We've all been frustrated by instruction manuals that don't instruct, so we tried very hard to create one that instructs, inspires, and entertains. Throughout this manual you'll see some special little sections that stand apart from the main text. They will look like these:

Whenever there's an important point that needs to be discussed before going on with the job, we'll pause and take a **Coffee Break...**



## How Tight Should That Fabric Be?

Let's talk about how tightly you should be attaching the fabric. How taut you pull the fabric as you... etc etc.

Whenever we need to make a short point of information during the project, you'll see this **Note...**



**Note: A squeegee is an excellent tool to use when cementing. Keep a few around and clean them regularly.**

This means, "**Take notice of this!**"

If there's a point that's really important or that deals with basic safety, you'll see one of these **Warnings...**



**Never apply an iron hotter than 250° to a cemented area. Doing so could release the seam or the bond!**

It means, "**Read and heed, Jim! This is MAJOR important!**"

## About the Other Cartoons...

Here and there you'll see cartoons like this rescued from pilot training manuals of World War II. For those of you who were there, we think they'll be delightfully nostalgic. For younger builders, they're a humorous glimpse into what was perhaps the richest, most patriotic part of America's past.

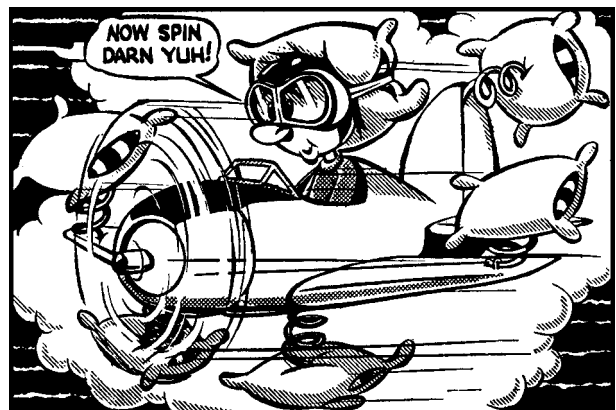

# NOTES

---

---

---

---

---

---

---

---

---

---

---

---

---

---

# 1 - Getting Ready

---

## The Goal of This Manual

---

We hate to see builders shy away from fabric-covered aircraft projects because they don't think they can handle the covering and finishing. They're depriving themselves of a very satisfying experience, and for no good reason. Fabric covering is not hard to do. Today's methods and materials are huge improvements over what was available back in the '30s. All it takes today is careful work and patience. There's no magic required. Really.

This manual can take even a complete novice through the entire process of re-covering a restored classic or covering a newly-constructed homebuilt. The steps are the same. In either case, we'll assume you're familiar with the construction of the aircraft you're covering. If you don't really know your way around your aircraft, we strongly suggest you get some experienced help before you begin.

---

## There Are Two Different Systems Using Ceconite Fabrics

---

The Ceconite STC (Supplemental Type Certificate) embraces two completely independent systems of coatings and paints. Once you choose one, you must use only the products called for by that system, or you will invalidate the STC, and your finished aircraft will not be legal or even airworthy. The choices are:

- **Ceconite/Randolph** combines Randolph nitrate and butyrate dopes with Ceconite fabrics. It has its own special techniques and products and a separate manual. This system has a record of success spanning 50 years.
- **Ceconite/Star Gloss** combines vinyl and polyurethane coatings with Ceconite fabrics.

## What Is It?

**Star Gloss is an aircraft fabric covering system that consists of special proprietary vinyl and polyurethane coatings applied over Ceconite polyester fabric.** Under the Ceconite STC, you can replace the original covering that was on your aircraft when it left the factory, probably Grade A cotton and cellulose dope, with the **Star Gloss** system. However, it does not license you to get creative and depart from this manual in any way.

### The Ceconite STC Number

In the past, Ceconite had a specific and different STC number for every fabric style then offered. Ceconite now uses only one STC number, SA4503NM; this one number applies to all fabric styles. Use this STC number for logbook entries and 337s.

### Certified Aircraft - The Basic Rules

In order to fly a safe and legal certified aircraft, you must follow these basic rules. For amateur-built aircraft, we encourage you to stay within these rules for a safe cover job with proven performance.

1. You must use the most current revision of this manual. The date of revision must be entered in all aircraft documentation and logs. Using an outdated manual voids the warranty.
2. Products applied to a certified aircraft must have a **Parts Manufacturer Approval (PMA)**. Ceconite fabrics, tapes, and cements, and **Star Gloss** coatings and paint all have PMA.
3. You must not interchange procedures and products in this system with those in the **Ceconite/Randolph** system.

## 1 - Getting Ready

4. You must use only **Star Gloss Gray Sealer** and **Silver Urethane Fabric Primer** in the build-up process. You cannot substitute coatings from any other system.
5. You must use only **Randolph Ranthane** as topcoat paint over fabric components. Using any other topcoat paint voids the STC.
6. You must heat tighten with a calibrated iron only. Heat guns may not be used.
7. You must not permanently cover critical inspection ports. For example, some aircraft have inspection ports in the aft portion of the wing, aileron, or flap wells that allow inspection of the spar. These holes must not be permanently covered. If in doubt, refer to the original aircraft maintenance manual.

**SUBSTITUTIONS WILL VOID THE STC AND YOUR AIRWORTHINESS CERTIFICATE IF DISCOVERED BY A SAVVY INSPECTOR AT ANY TIME DURING THE SERVICE LIFE OF YOUR AIRCRAFT. DON'T RISK IT!**

When you have finished your re-cover job, an A&P with an IA must complete an FAA Form 337 to certify that the aircraft was re-covered according to the Ceconite STC. He must also make the appropriate entries in your logbook.

The **Approved Model List (AML)** of certified aircraft eligible for re-covering under the Ceconite STC starts on page 95. Most aircraft have been added during the 50 years the STC has been in effect, but if yours isn't there, you can have it added to the AML by completing the Ceconite/Star Gloss Installation Form on page 93. An A&P can fill this out and mail it to us for processing.

### Amateur-built Aircraft

On the other hand, if you're covering or re-covering an amateur-built aircraft with

an *Experimental Airworthiness Certificate*, our STC doesn't apply as gospel. However, it's a good idea to follow the steps in this manual just as though you were working with a certified aircraft. AC 43.13 can also serve as an excellent guide. You can get a copy of it from one of the homebuilders' supply companies.

Simply passing an airworthiness inspection is no guarantee that what you have done is safe. Don't second-guess the experts. Follow instructions carefully and completely.

### The Fabrics to Use With Star Gloss

Our **Ceconite 101 and 102 fabrics** may be mixed or matched on every aircraft included on our STC. Both are manufactured under

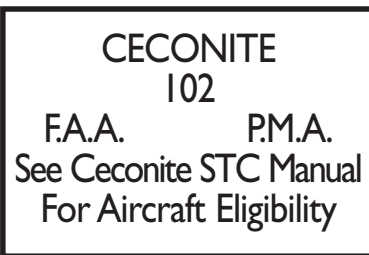

our PMA and are included in our STC. Remember, **you MUST use only Ceconite 101 and/or 102 fabric to**

**comply with the STC.**

Both are marked with a stamp like the one shown here. These stamps appear on our fabrics and are a sure-fire way to identify a genuine Ceconite fabric.

**Ceconite UNCERTIFIED LIGHT** is an uncertified fabric and is not approved for certified aircraft. It is approved for covering plywood surfaces on any aircraft, certified or uncertified. It may be used for any uncertified ultra-light. **Ceconite UNCERTIFIED LIGHT** fabric is not stamped.

We publish a *Fabric Product Data Sheet* (currently 2008-1) that presents and explains test reports on all three of our fabrics. We'll be happy to recommend a fabric style to fit your airplane. Just call our **Ceconite Tech Support Line, 800-362-3490.**

## 1 - Getting Ready

Ceconite finishing tapes, reinforcing tapes, threads, and cords have a sticker attached that says "Ceconite FAA PMA." Products without this sticker are not legal for use with our STC.

### Health Issues

#### Protect Your Skin!

Serious allergic reaction to some chemicals can show up **years** after exposure to them, so protect yourself now. Start with a barrier hand cream, like *Invisible Gloves*, available from all the supply houses. Then top that off with some of those disposable latex surgical gloves. They're cheap, so you can don new ones whenever solvents begin attacking the ones you're wearing.

#### Protect Your Lungs and Body!

**Star Gloss** is a polyurethane system. Polyurethane paint and coatings offer great advantages over conventional paint: high gloss, color fastness, and a tough flexible coating that gives an extremely long service life. In fact, polyurethanes are now almost exclusively the norm in automotive and industrial applications.

**WARNING:** The polyurethane coatings in systems like ours are catalyzed with polyisocyanates. Breathing the spray mist of isocyanates must be avoided; they are extremely toxic. **You must have a supplied-air type respirator to spray polyurethanes! Don't even consider spraying Silver Urethane Fabric Primer and Ranthane without one!**

Supplied-air respirators, sometimes called fresh-air respirators, are simple and effective. Essentially, they are blower systems that force clean fresh air into a mask. The slight overpressure in the mask prevents any possibility of breathing the toxic spray mist of polyurethanes. Professional automotive painters wouldn't consider spraying a *drop* without one. You need one, too.

No, a regular charcoal mask won't hack it; you need a supplied-air system.

We recommend one of the fine fresh-air breather systems made by **Axis Products**, [www.axisPro.com](http://www.axisPro.com). Axis makes a stand-alone breather called the **HobbyAir** that works well and is reasonably priced.



Axis also makes a fine combination turbine HVLP spray system complete with gun, hoses, and a built-in fresh-air breather system. If you need a spray rig, you might consider their **Citation** spray system with fresh-air breather.



Wear a Tyvek spraying suit or old clothes with long pants and a long-sleeve shirt. If you spill solvent on yourself, remove the clothes, wash your skin well, and put on fresh work clothes. Wash the first outfit promptly.



There's a right way and a wrong way to dress for spraying. Can you tell which is which above?

#### Protect Your Eyes!

At some point in your project you're bound to spill or slosh or spatter something. **Wear safety goggles** in any situation where that might occur. **Don't take chances!**



#### Fire Prevention

**Work in a well-ventilated area.** Some of the products used in the **Star Gloss** system are

## 1 - Getting Ready

highly flammable. While they are being used, potentially explosive vapors accumulate. Make sure there are no open flames such as gas water heater or furnace pilot lights anywhere near your work area. Lay down the law to visiting kibitzers. Outlaw all smoking. Be aware that even a sparking electric motor or a light switch could trigger a no-fun afternoon. Seek out all potential sources of flame or spark.



Have the right kind of fire extinguisher on hand, one designed for petroleum fires, and make sure it is fully charged.

Under certain circumstances, especially in warm weather with low humidity, the action of sanding or spraying can generate static electricity. When this static charge is transferred to the fuselage or other part, the resulting spark could ignite solvent vapors explosively. Ground the structures being sanded or sprayed. Some builders even ground their spray guns.

---

### A Practical Work Area

---

**Make sure you have enough room to work.**

You not only need room for the fuselage, wings, and other structures, but you also need plenty of room to walk and work around them without knocking things over or backing into fresh paint.

**Basements are poor choices due to lack of ventilation and potential fire hazards.** Not only that, but the solvent vapors will rise right up in to the house above. Garages are better. Empty hangars are best. Just make sure you have plenty of room and that the area is as clean as you can make it. Dust and junk floating in the air will wind up in your nice new finish, guaranteed.

**Ventilation fans are very desirable.** They'll help with vapors, sanding dust, and spraying

mist. Under no circumstances should you work in a closed room with no ventilation!

**The floor of your work area should be able to stand getting wet.** During the sanding, it will occasionally be necessary to flush the surface with water. It also means you'll need a source of running water within hose distance.

### Atmospherics and Spraying

In a perfect world, your work area would always remain at 77°F with 0% humidity, the accepted laboratory standards. Fat chance. The best tool you have for climate control is your calendar.

**Temperature:** Use your head, try to spray above 60 degrees and below 90 degrees Fahrenheit.

**Humidity:** For best results, spray when the humidity is less than 80%. Above that, the water vapor in the air can react with the polyurethane catalyst resulting in a loss of gloss or milkiness in the finish. Use your head; spray when the humidity is low. If you live in South Florida where the humidity is high all the time, spray a small test area, let it dry overnight, and check it for normal gloss and drying time. If it looks OK, press on.

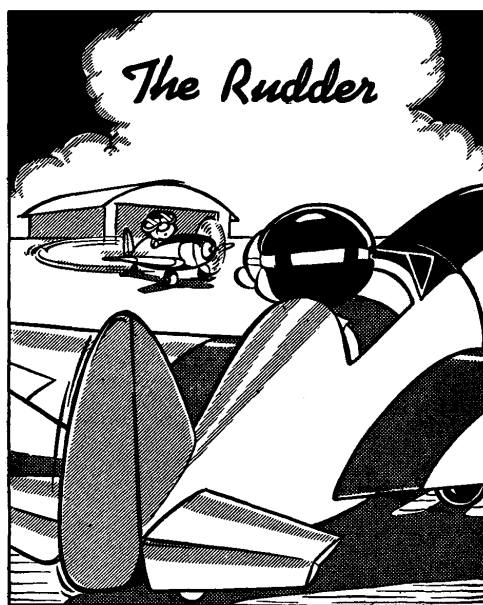

## 1 - Getting Ready

### Tools You'll Need

#### Let's start with an ideal list.

- Fuselage holding and turning jig. We'll talk about this later.
- Sturdy sawhorses, about 3' high. Pad the tops with carpet scraps. Great for wings and tail surfaces. We'll go into detail later.
- A nice big sturdy snag-free table will make handling and cutting fabric much easier.
- Drop cloths to protect floor, cover airframe parts, etc.
- An electric clothing iron. Don't use the wife's!
- A small sealing iron. Great for smoothing tapes, patches, and hard-to-reach areas.
- Thermometers to calibrate the irons
- Heat sink compound
- A supplied-air respirator
- Brushes: 1", 2", 3", and 4"
- Glue brushes, 1/2" wide (acid brushes are good)
- Sandpaper: 400 grit wet or dry
- Two 12" straight and two 12" curved rib lacing needles
- Sharp scissors; polyester fabric dulls them quickly, so buy several cheap pairs.
- Pinking shears. Buy a good pair and wear them on a cord around your neck; if you drop them, they're ruined!
- Sharp **X-ACTO** or other similar knife
- Paint spray gun and accessories
- Cotton rags. Do NOT use shop rags; they aren't clean enough, and residual silicone will ruin your work.
- Paper towels
- **Scotch-Brite** pads, ultra fine
- Single-edge razor blades, a big box
- Chalk snap line
- Measuring tape
- Paint stirring paddles
- Paint filter cones, 60x48 mesh
- Soup ladle
- Lots of clean soup and coffee cans with tight lids
- Small wide-neck container to use as a glue pot
- Craft masking paper – don't use newspaper.
- Six spring clamps with 2" throats - for holding fabric
- Wooden spring clothespins – great for fabric work
- T-head pins
- Tack cloths for cleaning just before painting

#### Fuselage Holding and Turning Jig

You can make a simple jig from two-by-fours, as shown here. The center square of the two-by-four "tic-tac-toe" grid bolts to the front of the fuselage using the engine mount bolt locations. Make the legs long enough for the

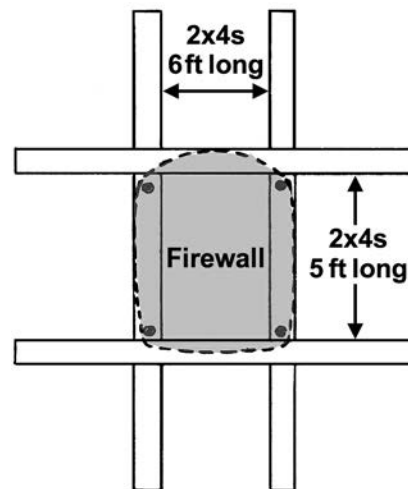

fuselage to sit level with the tail resting on one of your sawhorses. You and your helper can then turn the fuselage whenever needed.

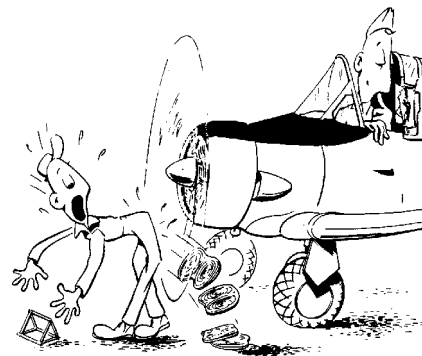

When running engine up to high power, be careful to have stick back and brakes applied.

## 1 - Getting Ready

### About Spray Guns

Don't skimp here! After all your careful and patient preparation, this is where "the rubber meets the road." You can ruin your entire job by trying to pinch pennies and using "bargain" spraying equipment. Don't do it. You'll hate yourself.

Most spraying is done with a compressed air system capable of at least 40 pounds of pressure AT THE GUN. Measurements taken at the compressor tend to be higher than the actual pressure delivered at the gun itself. **Don't get fooled.**



### If You Use a Compressed Air System:

- You must have filters and a water trap on the air line.
- Cleanliness is everything. The gun must be disassembled and thoroughly cleaned after EACH USE. Borrowed guns are never clean enough, and rented guns are usually junk.
- Pressure pot lines become coated inside with whatever's been sprayed. Solvents in subsequent spraying can loosen this old material which then contaminates *your* job. Replace pressure pot lines often.

The newer turbine-powered **high-volume, low-pressure (HVLP)** sprayers are terrific. They're expensive, but well worth it. Buy one with a few friends or have your club or chapter buy one for everyone to use. When you factor in the cost of the compressor, tank, lines, filters, water traps, and standard guns of a compressed air system, the cost of an HVLP isn't really that high at all. And the HVLP systems are self contained, more or less turnkey. All you need is 110 volts.



Use two lengths of hose with turbine-powered HVLP systems. HVLPs heat the air delivered to the gun, sometimes up to 90°. The extra length of hose solves this problem.

Regardless of the system you use, use the needle, aircap, and nozzle combination recommended by the manufacturer for the type of paint you're spraying. This information is usually found in a chart provided with spray guns. **Star Gloss** products work well with any combination rated for enamels or automotive polyurethanes.

Sorry, but those inexpensive airless sprayers designed for latex house paint won't work for aircraft.

---

## Materials You'll Need

---

Naturally, your list depends upon what you're covering, and you can scale things up or down as needed. We'll use a J-3 Cub as our example.

### Here's our list:

- 45 yards of **Ceconite 102 fabric**
- 1 roll of 1" **Ceconite 102 finishing tape**
- 7 rolls of 2" **Ceconite 102 finishing tape**
- 2 rolls of 3" **Ceconite 102 finishing tape**
- 1 roll of 4" **Ceconite 102 finishing tape**
- 1 roll of 4" **Ceconite Bias finishing tape**
- 1 roll of rib lacing cord
- 2 rolls of 1/2" reinforcing tape
- 2 rolls of inter-rib brace tape
- 1 roll of cloth anti-chafe tape
- 100 plastic drain grommets
- 30 inspection rings
- 30 inspection ring covers
- 1 gallon **Star-Tak** cement
- 5 gallons **Gray Sealer**
- 2 gallons **Gray Sealer Reducer**
- 4 gallons **Silver Urethane Fabric Primer**
- 4 quarts **Silver Urethane Fabric Primer Catalyst**
- 5 gallons **Ranthane HS Polyurethane** top-coat paint
- 10 quarts **Ranthane AU-CAT2X1 Catalyst**
- 4 gallons **G-4200 Ranthane Thinner**



# 2 – Airframe Preparation

---

## Take Your Time

---

The hours you spend preparing for the minutes you'll spend spraying will bring you years of enjoyment. Keep that in mind. There's no shortcut to thorough, meticulous preparation.

---

## The Right Stuff: Epoxy

---

Whether you're preparing a steel, aluminum, or wood structure, don't use any of the familiar one-part zinc chromate primers or "spar varnishes," the type you find in hardware stores. The fabric cements and dopes used in covering aircraft will wrinkle and lift them.

Use only two-part epoxy primers or varnishes; they are unaffected by cements and dopes. Two-part epoxy products may also be sprayed right over old zinc chromate or varnish for a safe attachment surface and additional protection from the elements.

---

## Wood Surfaces

---

Dry-sand old flaking varnish scale. You needn't remove all the old varnish, just the loose parts. After sanding, wipe the surface with **Randolph C-2210 Paint Cleaning Solvent** to remove any grease and contamination. Then wipe with a clean dry rag.

Now apply **Randolph EV-400 Epoxy Varnish** directly to the surface. Use our **EV-410 Catalyst**, and thin as instructed with **E-500 Epoxy Thinner**.

---

## Steel Tubing

---

If you are re-covering a tube-and-rag airplane, you must first remove ALL the old fabric. Once you do that, you'll be presented with tubing

structures loaded with old primer and cement. There may also be some rust. **If the rust is extensive**, you are probably facing some metal repair. Examine the structure carefully, marking areas that will need fixing. Make all needed structural repairs now, replacing damaged tubing or other members in accordance with accepted standards and practices.

Now you must remove the old cement, paint, primer, and rust **WITHOUT** pitting or damaging good metal under it. The best way to do this is by blasting it with one of the many media now available. Test a painted tubing scrap first. Find the combination of air pressure and media that will remove the paint and leave everything else.

Now that the structure has been repaired and stripped, the metal must be protected as soon as possible. Letting more than an hour or two go by between blasting and priming invites new rust to begin forming. Be sure to have everything you need – cleaner, primer, catalyst, reducer, spray equipment, and spraying area ready to spray – **BEFORE** you start blasting.

Immediately before priming, wipe the bare areas with **MEK** or **E-500 Epoxy Thinner** to remove all traces of oil, grease, and contamination. Wipe dry with a clean rag, **NOT** a shop towel.

Finally, prime with **Randolph Epoxy Primer**. Randolph offers two colors of epoxy primer: **White W-2248 Epibond** and **Dark Green B-6433 Rand-O-Plate**. Whatever color you choose, remember that **Randolph Epoxy Primer** kits have three parts. Part one is the white or green primer, part two is the **EP-430 Catalyst**, and the last part is the **E-500 Epoxy Thinner**.

You need all three parts to do the job. See Appendix G, Product Profiles, at the end of this manual for a thorough explanation of mixing, application, shelf life, packaging, etc.

## 2 – Airframe Preparation

---

### Fiberglass

---

Many raw fiberglass parts are pretty rough and require some filling. Fill big holes or weave with **Poly-Fiber SuperFil**, available from most **Poly-Fiber** distributors. **SuperFil** is sort of Bondo for airplanes; it works the same way, but as an epoxy product it gives long service and works on any composite part. Apply **SuperFil** with a squeegee, let it dry overnight, then sand smooth. Prime with **Randolph White 2248 Epibond** (refer to the section above for details). You may need to spot spray multiple coats of **Epibond** into the areas filled with **SuperFil**. Since **SuperFil** is more porous than most finished composite parts, this spot spraying and sanding will give a smooth overall surface to the whole composite part.

---

### Aluminum

---

#### Old Aluminum

After stripping, inspect carefully for corrosion. If there is any corrosion present, it must be removed before you go any further. Use fine sandpaper (NOT emery), Scotch-Brite pads, or aluminum wool. Do NOT use steel wool or a steel brush. This just introduces tiny bits of steel into the aluminum which will promote even worse corrosion. Avoid blasting. It is very hard on aluminum sheet.

Old aluminum must now be acid etched, treated with a conversion coating, and then primed for best results.

Thoroughly wash all the aluminum parts with **Alumiprep 33**. Follow the manufacturer's instructions. Use an ultra-fine Scotch-Brite pad.

Rinse thoroughly with clean water to insure that no etch is trapped in seams or under rivet heads.

Next, wash with **Alodine 1201**. Follow the manufacturer's instructions. Wash and keep wet with a sponge for at least five minutes. Rinse with clean water and allow to dry completely.

Prime with **Randolph Epoxy Primer**. We recommend using **Randolph W-2248 White Epoxy Primer** over aluminum. Remember that there are three components to our epoxy primer systems; you must also have **EP-430 Catalyst** and **E-500 Epoxy Thinner** to get the job done. See a complete explanation of epoxy primer in Appendix G, Product Profiles, at the rear of this manual.

#### New Aluminum

There is no need to use **Phosphoric Acid Etch** on new aluminum. First wipe the new aluminum surface with MEK, Acetone, or Toluene to remove any packing oils. If the new aluminum has an Alclad surface, gently scuff the entire surface with an ultrafine Scotch-Brite pad or 320-grit sandpaper to impart some tooth adhesion. Be careful not to leave noticeable scratches in the Alclad; go easy.

Next, wash with **Alodine 1201**, diluted with two parts water. Wash and keep wet with a sponge for at least five minutes. Rinse with clean water and allow to dry completely.

Prime with **Randolph Epoxy Primer**. See the directions in the paragraph above on *Old Aluminum*.

---

### Dealing With Dents and Imperfections

---

Nothing looks worse than a new covering job with dents and old damage showing through. Maybe you taxied into a hangar door, or a hail storm tattooed your airplane, or maybe there are some low spots in those plywood fairings. Take the time now to smooth or correct them. Once the new fabric is installed, it's too late. Here are some suggestions.

#### Replace Badly Damaged Areas

If the damage is severe or extensive, you might be better off just biting the bullet and replacing the material. The time you take installing nice

## 2 - Airframe Preparation

smooth new aluminum or plywood will pay for itself later in the praise your airplane will get from jealous onlookers.

### Fill With Poly-Fiber's SuperFil

**SuperFil** works great on wood, fiberglass, steel, and aluminum. It really grips the surfaces, and stays flexible enough over its service life to keep from cracking. **DON'T USE BONDO!** Bondo is **heavy!** Bondo will shrink over time and separate from the surface. Bad news. And Bondo is made from polyester. You need epoxy products.

Apply **SuperFil** with a squeegee, and work it into the basic shape you want. After 12 hours, **SuperFil** will be ready to sand and smooth. Apply primer to **SuperFil** used on aluminum; apply varnish to **SuperFil** used on wood.

Make a point of reading the **SuperFil** instructions. Remember to thoroughly stir each of the two parts before mixing them. Mix them carefully, by either weight or volume. "TLAR" mixing ("That Looks About Right") doesn't fly when you're working with epoxy.

---

### Inter-rib Bracing

---

This bracing keeps the ribs straight up and down when the fabric is heat tightened over them. It is nothing more than twill tape to provide stability for the ribs while covering. As the drawing

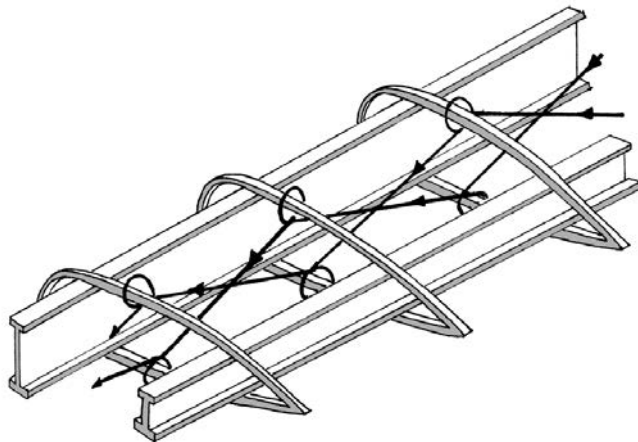

shows, the tape is looped around the top capstrip of the first rib halfway between the front and rear spars. Then it loops around the bottom capstrip of the next rib, and then back to the top capstrip of the next rib, and so on until the whole wing is braced.

When complete, the inter-rib brace looks like a series of "Xs" in each rib bay. It is important to only loop the inter-rib bracing without tying it to each rib, except at the very ends. If you tie it, the ribs won't be able to move and readjust their positions during the tightening process. This bracing is not removed.

---

### Anti-chafe Tape

---

Any sharp edge or structural feature that might cut or poke through the fabric should be covered with cloth sticky-back anti-chafe tape. It's self adhesive and easy to use.

There's no hard and fast rule about where to put this tape. Obviously, it should go over rivet heads, metal seams, and sharp edges that could cut the fabric. You don't need it over smooth ribs or well-prepared wood or aluminum. Let your sense of touch be your guide. If you feel something sharp or pointy, put some tape on it.

**CAUTION:** Don't go crazy with anti-chafe tape and make your airplane look like the mummy's revenge! Wherever you cement something to anti-chafe tape, that bond is only as strong as the sticky adhesive on the underside of the tape! Keep tape off places where you need a good **Star-Tak** bond.

**NEVER** use paper masking tape, duct tape, or aluminum-faced tape instead of real **Ceconite** anti-chafe tape! All of these retain water and will bring about rust or corrosion on metal under them. Also, paper masking tape turns brown with age and will show through light-colored paint. *Very ugly.*

# NOTES

---

---

---

---

---

---

---

---

---

---

---

---

# 3 - Tune Up Your Iron

From this point on you will be using your iron to install fabric and smooth any wrinkles that appear. Now's the time to prepare your iron for use.



**The only authorized heat source for accurate control of the temperature transferred to fabric is a CALIBRATED CLOTHING IRON. Period.**

## Heat Guns? No!

How come you can't use your heat gun? Because there's no way to calibrate it, and the temperature changes as the gun's distance from the fabric changes. You run a tremendous risk of permanently loosening your fabric and ruining all your nice work. Leave the heat gun for removing paint and for emergency corn popping.

## The Right Iron

### Avoid Irons With Automatic Shutoff!

Understand that individual irons vary. Make sure they are 1100 watts minimum.



There may be some non-load carrying areas that can't be reached with a standard size iron,

places where exact fabric tension is not important as long as the wrinkles are removed. For these areas we recommend a small **165-watt**



**heat sealing iron.** It's available through Ceconite/Star Gloss distributors. It should be calibrated the same as your large iron and used only to smooth the edges of trim tapes and patches and in areas not subjected to flight loads because these little irons can't maintain their temperature in contact with a large heat sink area.

## Why Calibrating Your Iron is So Important

Polyester fabric does different things at different temperatures, and we take advantage of this to make the fabric do what we want when we want.

- \* **225°** is used to smooth the edges of finishing tapes and patches, heat form fabric around corners, and remove fold creases.
- \* **250°** is used for the initial tightening.
- \* **350°** is used for the final tightening.

Above 350° the fabric gets looser, permanently looser! At about 375° polyester filaments start to thermo-soften and lose all measurable tension. At 415° they start to disintegrate. Not good at all. You can see why calibration is so important. **Don't just guess or assume your iron's dial is accurate.**

### 3 – Tune Up Your Iron

---

## How to Calibrate Your Iron Correctly

---

You need an accurate thermometer with a stem that can be placed in contact with the plate of your iron, plus **some silicone heat sink compound**, available from **Ceconite/Star Gloss** distributors.

An accurately calibrated low-cost glass thermometer is available through **Ceconite/Star Gloss** distributors. A deep fry, candy and jelly thermometer, available at hardware stores, is another economical choice. Remove the protective glass shell, check the calibration in boiling water (212° at sea level), then secure the calibration card with cement.

- Put a nice big glob of **heat sink compound** on the bulb end of your thermometer.
- Build a ½"-thick stack of dry paper towels on your workbench.
- Lay the thermometer bulb in the center of the paper towels. Place your iron on top of the thermometer bulb and the towels. **Make sure the bulb is in contact with the plate of the iron.**
- Advance your iron's heat control knob and watch the thermometer. Give your iron time to change temperature, and give the thermometer time to react.
- When the thermometer has settled down at **225°**, mark your iron's dial. Use something visible and removable. You'll probably have to change your calibration marks at some future time.
- Now do **250°** and **350°**.

**Always use the same extension cord;** a different cord could give you different readings.

Your iron should hold the desired temperatures,  $\pm 10^\circ$ . It should be recalibrated at the start of each new covering project or if it is dropped.



---

**SUPER IMPORTANT! After calibrating is finished and your iron has cooled, carefully remove all traces of the silicone heat sink compound from the sole of your iron!**

---

# 4 – Attaching the Fabric

## Cemented Seams

Our fabric is attached with **Star-Tak** cement, using cemented seams. A cemented seam is a place where **Star-Tak** is used to join two pieces of fabric where they contact an airframe structure, as when covering a wing, for example. There is virtually no sewing to do, unless you want to.

### Approved Cements

**Star-Tak** is the only cement approved for the Ceconite/Star Gloss STC.



In our STC, cemented seams are approved for any airspeed and any wing loading if you follow these rules:

- All seams require at least 1" overlaps of the two pieces of fabric.

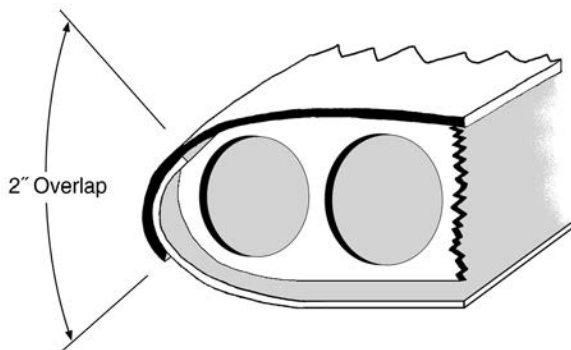

- Wing leading edge seams require 2" fabric overlaps.

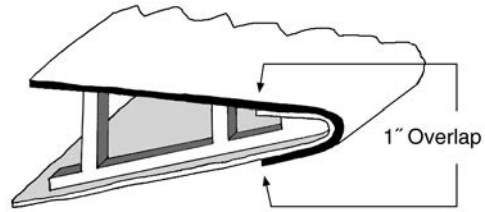

- Wing trailing edge seams require 1" fabric overlaps.
- All cemented seams must be covered with finishing tape at least 2" wide. You can use wider.
- All cemented seams must lie over structural parts of the airplane, and those structural parts must be at least as wide as the cemented seams.

So what's a structural part of the airplane? On wings, it's the leading edge, trailing edge, the tip bow, and the butt rib. Ribs are not considered structural.

On control surfaces, it's leading and trailing edges or the perimeter tubing.

On fuselages, it's the longerons or main cross tubes that are part of the load-bearing structure. Wooden formers or stringers that are there just to give shape aren't considered structure.



**All fabric edges that will overlap as part of a cemented seam should be cut with STRAIGHT SCISSORS.**

## 4 - Attaching the Fabric

**Here's a great way make a sharp cut with no loose threads or ravel:**

1. Draw your cut line with a soft lead pencil.
2. Coat the line with a thin coat of **Star-Tak**.
3. When dry, cut with straight scissors.
4. *Voila!* A crisp, sharp cut!

---

### The Cementing Process

---

Use a soup can for the **Star-Tak**, and apply it with a 1"-wide gluing brush. If the **Star-Tak** gets thick in the soup can, add pure MEK to get it back to the original consistency. If you spill or have a messy area with excess ooze or drips, clean it up with MEK. MEK will clean up even dried **Star-Tak**.

**Star-Tak** dries fast... *really* fast. In hot weather it can dry in five minutes. It normally dries in about 15 to 20 minutes.

Because **Star-Tak** dries so fast, you have to brush it on a little at a time, then stop and press the fabric into it while it's still wet. Normally, you only cement about 12" to 18" at a time to keep it from drying. The trick is to keep the cement liquid when the fabric is placed into it. If it dries, that's no good. You must do it again.

The best cement bond is accomplished by brushing about a 1" wide strip of wet **Star-Tak** onto the area where fabric is to be attached, then immediately laying the fabric wrinkle-free into the cement. Force the cement up through the fabric until it wets out the surface. Use your fingers (you do have on your barrier cream or latex gloves, don't you?) to smooth the fabric into the wet strip of cement, making sure it penetrates the fabric. Better still, use a squeegee.

If you make a mistake, you can uncement any seam. Simply wet the seam with MEK on a rag, pull the seam apart, and immediately

re-cement it correctly with fresh **Star-Tak**. You can't make a mistake here that MEK can't fix.

---

**Don't brush more Star-Tak over the top surface of a drying cemented seam. Resist this temptation! Doing so could hurt the bond. The top coat will dry before the original bottom coat, impeding drying of the bottom.**

---

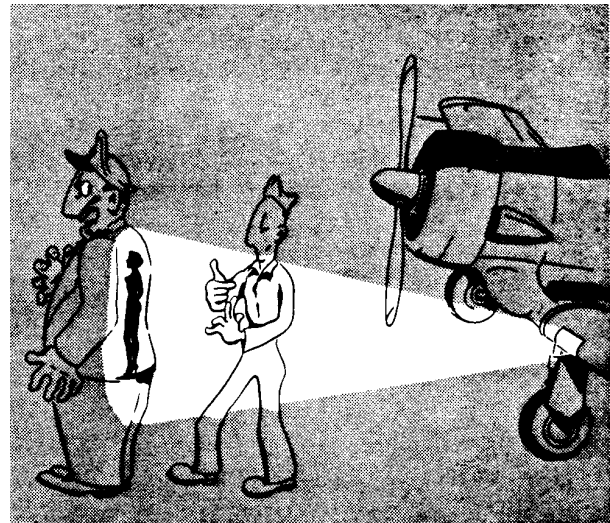

Before setting out on a night flight, check your airplane's lighting system.



# 5 – Let's Do a Wing!

You're going to cover a wing from start to finish, right up to where you're ready to begin building up the final coating. Once you understand the steps involved, you'll be ready to tackle the rest of the airplane.

## Basically, the steps are...

1. Cement the new fabric to the wing.
2. Heat-tighten the fabric in stages.
3. Brush on the 1st coat of **Gray Sealer**.
4. Rib-lace the fabric to the wing.
5. Apply finishing tapes and inspection rings.
6. Smooth rough tapes and imperfections with the iron.

All the prep work discussed earlier, priming, varnishing, inter-rib bracing, anti-chafe tape, etc., is done, right?

If you have control cables installed, or electrical wire for lights, pull them all normally taut and secure them that way with clamps or tape or whatever.

You'll use the **blanket method** to cover this wing. A blanket is simply a rolled-out length of fabric cemented to the wing. **Ceconite fabrics** are about 70" wide, so they can easily cover almost any normal wing. If you have an unusually wide chord, two pieces of fabric can be sewn together to make a wider blanket. Or you might be able to use three pieces of fabric with an insert, as long as you follow the basic rules for cemented seams. If you think you'll need to sew fabric together, see Appendix A for information on sewn seams.

## Handy Sawhorses

The best way to hold the wings for covering is to rest them upon specially modified sawhorses. Two pieces of wood, typically 2-by-4s long enough to reach across at least two ribs, are fastened perpendicular to the top beam of each sawhorse. Space them the same distance apart as the spars.



Cover the whole shebang with scrap carpet. Position the sawhorses beneath the wing with the padded pieces parallel to the spars and directly under them.

---

## Covering the Wing, Step by Step

---

The game plan for this wing is simple. You'll use one long piece of fabric applied spanwise to cover the bottom of the wing and another for the top.

Following our basic rules on cemented seams, you'll join the top and bottom pieces with a 2" overlap at the leading edge and 1" overlaps at the trailing edge, tip bow, and butt rib. You won't cement fabric to the ribs themselves, since later you'll use rib lacing or some other mechanical means to hold the fabric to the ribs. Other common mechanical attachments are pop rivets, PK screws, and fabric clips. More about them later.

We're assuming your wing has an essentially flat bottom surface. However, if it's concave, you **MUST** instead go to Appendix B, Concave-bottom Wings, on page 65.

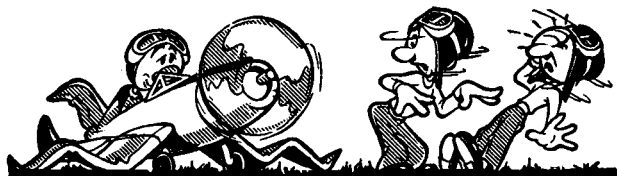

## 5 - Let's Do a Wing!

We'll start with the bottom of the wing first, although it doesn't matter.

### First, the Leading Edge

- Mix up some thinned **Gray Sealer**.

**The recipe is three parts Gray Sealer to one part Gray Sealer Reducer.**

- Brush two coats of this thinned **Gray Sealer** onto the leading edge to provide a "bedding" that will reduce the possibility of pinholes in the finish coat. Actually, all large metal, wood, or fiberglass parts that will be covered with fabric should get these two coats of **Gray Sealer**.
- Let this dry for about 15 minutes.
- Get out your chalk line and snap a line along the center of the leading edge. Then measure 1" above the center line and 1" below that center line and snap parallel lines at those marks. By the way, regular blue carpenter's chalk lines will disappear later and won't bleed through. These chalk lines will be your guide lines. Cement bottom fabric to this line.

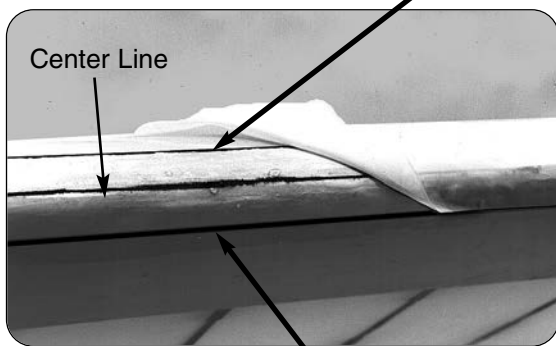

- Cement the top fabric to this line. If you use these lines when cementing, you are assured of straight seams with a legal 2" overlap.
- Roll out a piece of fabric to cover the bottom

of the wing. Trim off any selvage (built-up edges where threads are doubled over during looming). They may show through the finishing tape. Trim it off carefully with sharp straight scissors. Remember to first coat the cut line with **Star-Tak** for the sharpest line with no raveled threads. Flaws and ravels will show through later. If the selvage is straight and is not noticeably raised, you may choose to leave it on.

The fabric has no top or bottom. There's no special orientation to the weave. Attach it with the stamp in or out. Doesn't matter.

- Allow about an extra foot at the wingtip and the butt, and cut it off the roll. Clamp it in place with spring clamps or clothespins. Don't be afraid to remove the clothespins and move the fabric as necessary throughout the entire cementing process.
- Starting at the butt rib, brush a strip of **Star-Tak** about 2" wide (1" each side of the center line) and 12" to 24" long along the leading edge where the fabric will be attached. Line up the fabric edge with the appropriate cement line.



**Note: A squeegee is an excellent tool to use when cementing. Keep a few around and clean them regularly.**

## 5 - Let's Do a Wing!

■ Lay the fabric onto the wet cement. Work the fabric into the cement with the squeegee or your fingertips. Squeegees work better, and have the advantage of spreading lumps out. Work in short sections, applying tension to the fabric as necessary to keep the wrinkles out. Think ahead though. Make sure the whole piece of fabric is aligned and lying where you want it to be. Stop every now and then and look at the whole job. If you're unhappy with an area, un-cement it with MEK and do it again.

■ Continue this process, working 12" to 24" at a time, until the entire bottom section of fabric is attached to the leading edge. Let this dry for about 15 minutes.

### How Tight Should That Fabric Be?



Let's talk about how tightly you should be attaching the fabric. How taut you pull the fabric as you cement it at the trailing edge has a big effect on the final tension of the fabric when it's eventually tightened with the iron. Final tightening will shrink

the fabric about 10% overall.

On a wing 60" wide, that means it will shrink about 6". If for some reason you left 6" of slack in the fabric (and you certainly wouldn't want to do that), the fabric would pull up and conform to the shape of the wing, but would be far too loose.

On the other hand, if you pull the fabric as tight as a bedsheet in boot camp (remember bouncing a quarter off it?) and cement it down, and then tighten it, the resulting tension can warp or bend light structures. Stamped ribs or thin tubing can be deformed when the fabric is applied too tight.

As a good rule of thumb, the fabric should look like a bed sheet with the big wrinkles pulled out of it... snug, but not tight.

**OK... back to work.**

### Uh Oh... Protrusions!

Strut fittings and other attachment points can work like tent poles under the fabric. If a protrusion is less than 2" above the surface of the wing, you don't need to cut the fabric to make a hole for the protrusion before heat tightening. Leave the fabric intact and tighten it right around the protrusion. Don't worry, it won't rip through. More on this later.

If they are 2" or more, you'll have to make a cut to let the protrusion through. Brush some **Gray Sealer** over the area of the protrusion before you cut to keep the fabric from raveling around the cut. Make the smallest possible cut you can. Make sure the fabric is as close to its final position as you can before you cut anything. When you tighten the fabric, the hole will get a lot bigger, so take care.

### Next, the Trailing Edge

■ Pull the bottom fabric gently toward the trailing edge to remove wrinkles. Rough-trim it to overhang 6" minimum and secure it with spring clamps. Rough-trim the fabric so it will fold at least 1" down into any control surface recesses. Industrial single-edge razor blades are good for this. Inside corners of flap and aileron recesses are cut at a 45° angle to allow the fabric to fold down at the sides.

■ Cement the fabric to the **BOTTOM** surface of the trailing edge **ONLY**. Work from the butt rib to the wingtip in short sections, keeping the wrinkles out just as you did on the leading edge.

Now, before cementing the fabric to the **TOP** surface of the trailing edge, you're going to

## 5 - Let's Do a Wing!

heat-form the fabric around it. It's much simpler to pre-shape the fabric than to use clothespins, spring clamps or fingers to hold it in shape around the edge of the trailing edge while the **Star-Tak** dries.



**Warm up the iron to 225°.** You DID calibrate it, didn't you? It's VERY important!

- With your iron, roll the fabric around the trailing edge, working from the bottom surface around to the top. Apply pressure so it permanently creases and takes the shape of the trailing edge. If you stay with it, the fabric will not only crease around the corner, but will lay flat on the top surface of the trailing edge without using clamps. It should end up like this:

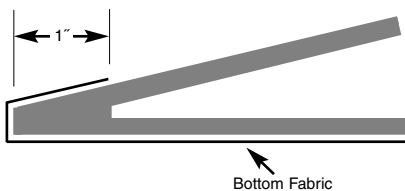

The reason you are wrapping the fabric entirely around the trailing edge is to make sure you wind up with a real overlapped cemented seam. Later, when you attach the top fabric, it will overlay this bottom fabric.

That's where the required overlap comes in. If you simply trimmed the fabric flush with the trailing edge and then cemented it down, you would have no fabric-to-fabric overlap.



**REMEMBER, you must always have an overlap.**

- Once the fabric has been heat-formed to assume the shape of the trailing edge, cement

it down and trim it off. Take care trimming. Uneven lines or raveled threads will show later.

### Now for the Butt Rib

- With the wing still top side up, start heat-forming (**225 to 250° iron**) the extra fabric at the butt rib. You want to cover the entire butt rib with fabric. Heat-form carefully to make the fabric bend around the corners and edges to assume the shape of the rib.

Heat-forming is best done by pulling the dickens out of the fabric (you can't tear it) and applying heat with the iron on the area to be formed. Stay with it; you can make the fabric take any shape you wish with enough practice and patience. Heat-forming gets rid of all potential wrinkles and keeps you from having to cut "darts" in the fabric. Darts are those ugly 45° slits we used to have to cut in cotton to make the fabric conform to curves. With pressure and patience, you can even form polyester fabric around a bowling ball with no wrinkles. True.

- When you've successfully formed the fabric, cement it to the butt rib. You may need to make some cuts for cables or wires.



**Never mark on fabric with anything but a soft lead pencil or a chalk line. Pens, magic markers, etc. will bleed right through your final paint. V E R B O T E N !**

- Trim the fabric even with the top edge of the butt rib. Later you will heat-form at least an inch of the top wing fabric around the corner and down onto the butt rib to make our 1" overlap.

### Aileron and Flap Recesses

- For aileron and flap recesses, heat-form the fabric into the recess and cement it securely.

## 5 - Let's Do a Wing!

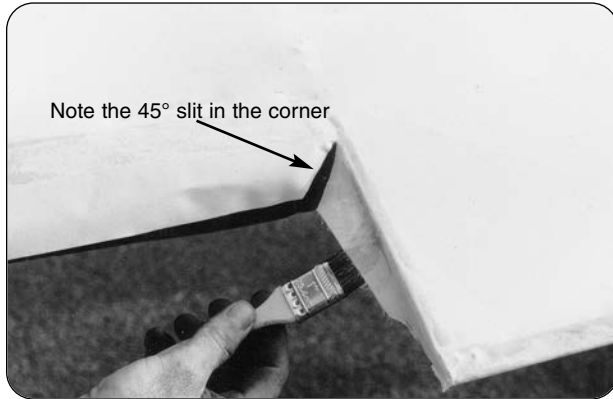

Put your fabric overlap inside the recess as shown.

### The Curved Wingtip Bows

You should have plenty of excess fabric left at the wingtip, hopefully about a foot. This excess gives you a good “handle” to pull on while heat-forming.

- Make a small “ironing board” out of cardboard, about 5” x 3”.

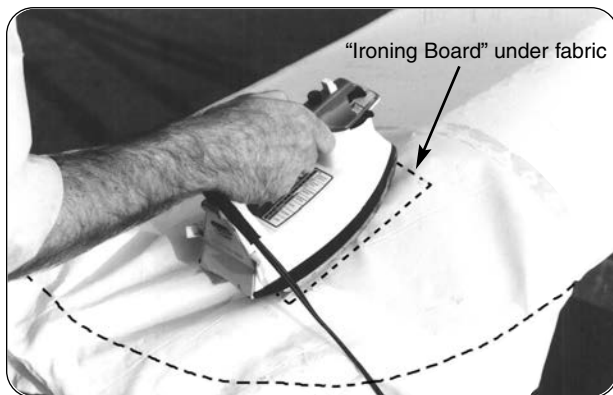

- Place the ironing board under the fabric about a foot in from the bow. Tighten this area at **250°**. This will help the heat-forming of the fabric at the tip. If you tighten the center of the radius, it makes it easy to make the curve at the bow.
- Now start rolling and heat-forming the fabric around the tip bow with the iron set at 250°. Roll and form the fabric as far as you can to the inside of the bow.



---

**Yes, sharp-eyed readers! This IS the TOP of our wing, just to show how the curvature is smoothed out. You should start with the BOTTOM of the tip bow.**

---

- Pull *hard* on the fabric around the bow and apply heat. The trick is to get the fabric wrapped around the bow at least an inch. More is even better. Whenever you can, wrap all the way around to the inside of the tube so the seam won't show.

**At some point, you'll have to turn the wing right side up to wrap the bottom fabric around the bow tubing.**

- When you have the fabric well formed to the inside of the bow, cement it down. Try to cement it in one application, rather than in short sections. You have to work fast, but you'll get fewer wrinkles.



## 5 - Let's Do a Wing!

A neat way to trim is to use a single-edge razor blade. Hold it firmly on the surface, and pull the fabric into the blade. Don't slice with the blade; you could cut the primer or fabric below.



- Let the **Star-Tak** dry for about 15 minutes after the bottom fabric is cemented all the way around the perimeter of the wing.

OK, now the bottom piece is on, and most of the basics have been done.

- Before you attach the top fabric, go over all the cemented areas with an iron lower than **250°**. Use enough pressure to take out all wrinkles.

The idea is to iron out all wrinkles or imperfections in the cemented areas of the bottom fabric before you cement the top piece over it. The smoother you can make the cemented areas, the better they will look later when covered with the top piece of fabric. **You are using the iron on JUST THE CEMENTED AREAS now.** You'll heat tighten the whole wing later, after the top piece is applied. Patience.

Notice how the iron can take out all the wrinkles that occur during the cementing process. Work carefully and stay with it until all of the wrinkles are gone. Use pressure and the tip of the iron. The iron also softens the **Star-Tak** below the fabric, allowing you to re-smooth any lumps. Use the little sealing iron in tight places.



**NEVER APPLY AN IRON HOTTER THAN 250° TO A CEMENTED AREA. DOING SO COULD RELEASE THE SEAM OR THE BOND!**

### Now For the Top Fabric

- Roll out the top piece of fabric. Clamp and trim it as before, with a foot extra at the tip and butt.
- Cement the leading edge, aligning it to the lowest chalk guide line. That line is now covered by the bottom fabric and may be hard to see. If so, re-chalk it.

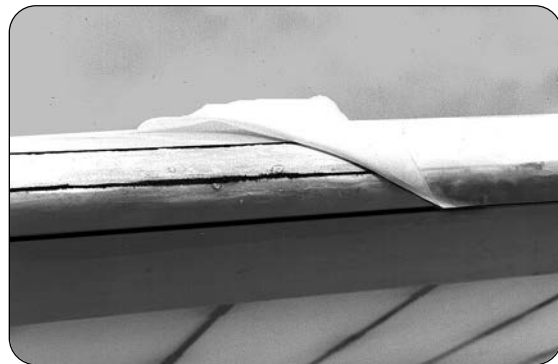

- Cement the trailing edge as before. For the best overlap seam, heat-form the top fabric around both sides of the trailing edge, and cement it to both sides. That will give you more than the required 1" overlap and a very strong seam.

If your trailing edge fairing is at least 1" wide, you can simply cement the fabric to the top of the trailing edge and trim the fabric off flush without wrapping it around. That would make a legal 1" overlap also.

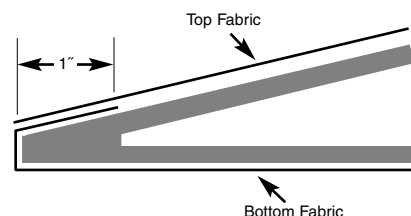

## 5 - Let's Do a Wing!

- Heat-form the top fabric over the edge of the butt rib until the fabric is smooth and flat. Keep forming until at least an inch of formed fabric lies flat over the butt rib. Trim this neatly and cement it to the fabric below making sure you have a legal 1" overlap.
- At the wingtip bow, heat-form the top fabric the same way you did the bottom. Make sure you have a 1" overlap where the top piece overlies the bottom. Trim the top piece with scissors as neatly as you can. Razor blades are dangerous here, you could inadvertently cut the bottom fabric while trimming the top.

### Before You Start Ironing...



OK, now the fun part. You're about to tighten the wing fabric with your **carefully calibrated iron**. The iron is ready, and the untightened wing is on the saw-horses. But first, a very important point.

❖ **Remember, a calibrated iron is the only approved heat source for tightening. Heat guns or uncalibrated irons are the surest way to damage your project or invalidate your STC.**



**If you ignore this and use a heat gun or an uncalibrated iron, you could wind up with permanently loose fabric! At best, this means cracked paint. At worst, it causes fabric floppy enough to seriously deform the airfoil in flight! Bad news.**

OK... back to work.

## Heat Tightening

**Make sure the iron is set to 250°.**

The idea is to spread the increasing tension

evenly and symmetrically across the surface. To do this, start at one end of the wing, say at the tip.

- Hold the iron in the center of the fabric near the tip bow. See the fabric pull up tight around the iron? Move the iron slowly around the fabric to take out the big wrinkles. Iron over the hard surfaces too, like the leading edge.

---

**Don't start at one end of the wing and work toward the other. This can exert enough asymmetrical force to bend light structures. You could put unwanted dihedral in your wing (or maybe you always wanted a "bent-wing" Corsair), or you could wind up with deep troughs in the fabric between ribs as the fabric is pulled spanwise in one direction only.**

---



- Now go out to the opposite end of the wing, by the butt rib, and do the same thing. Alternate your tightening at opposite ends of the wing, working toward the middle.

Don't be afraid of letting the iron pause on the fabric. It won't scorch the fabric like it does your cotton shorts. Nor will the fabric get any tighter. **The amount of tightness depends upon temperature, not time.**

- Turn the wing over and tighten opposing areas at **250°**, as you did on the top side of the wing.

**Now set the iron to 350°.**

Repeat the same process of heat shrinking when the iron stabilizes at **350°**. You may see some steam coming off the fabric as some of the moisture in the air or fabric sizing boils away. This is perfectly normal, nothing to be alarmed about.

## 5 - Let's Do a Wing!

**Remember not to iron over cemented seams with the 350° iron.** If you do, you stand a good chance of having the cemented seam fail when the top piece of fabric shrinks more than the bottom. So be careful, stay away from cemented seams with the **350° iron**.



**Make sure you get every bay of fabric shrunk at 350°. If you miss one it will be less tight than the rest; this will be apparent throughout the service life of the aircraft, so get it right.**

### Protrusions

Remember those strut fittings sticking up like tent poles 2" or less under the fabric? Iron right around them; they won't break through. Later, when the whole wing has been tightened at **250°**, cut the fabric just enough to let the protrusion pop through, and cut no more. The idea is to make the smallest cut you can.

## Brushed Coat of Gray Sealer

Applying **Gray Sealer** does two things:

1. It seals the fabric.
2. It acts as a cement that soaks through the fabric and further secures the fabric to the airframe.



**Gray Sealer should always be thinned three to one with Gray Sealer Reducer.**

**Gray Sealer** has a gray tint so you can see where it has been applied.

- Thoroughly wipe the fabric with a slightly damp clean rag of MEK or **Gray Sealer Reducer**. Don't flood the cement joints!

**Use only new rags. Cotton is best, but watch the lint. NEVER USE INDUSTRIAL SHOP RAGS OR LAUNDRERED RAGS. They're full of somebody else's silicone and impregnated grease that never really comes out. Rub a shop towel on your fabric and you may ruin it.**



Go to a builders' supply store and buy fresh **painters rags**. It's worth the expense. Or go to a fabric store and buy cheap **100% cotton cloth**.

- After wiping the fabric with MEK or **Gray Sealer Reducer**, follow by passing a tack rag lightly over the surface to pick up any dust or lint.

Cut an old rectangular can (like a reducer can) to make a nice **Gray Sealer** application bucket. The handle at the top makes it easy to hold while you are brushing. Stick a piece of rigid wire or welding rod through the side to wipe the brush on or hold it out of the liquid.

**Natural-bristle brushes are best for Gray Sealer. You can use high-quality polyester brushes, but avoid foam or nylon. They dissolve in solvents. Buy a good 3" brush for applying Gray Sealer to fabric, and a good 2" brush for applying finishing tapes later on.**



OK, get your bucket of thinned **Gray Sealer**, a good 3" brush, and a can of MEK or **Gray Sealer Reducer** with a rag.

- Brush **Gray Sealer** liberally over all the fabric. Brush all open fabric areas and fabric over the hard surfaces. The idea is to make the fabric look slightly shiny and wet, and leave no dry starved areas.

**This is no time to skimp!** You need to really wet the fabric to fill the weave. You may notice



## 5 - Let's Do a Wing!

gray runs forming on the inside of the fabric if you are really laying it on. This is perfectly fine, these runs just show that you are wetting out the back side of the fabric as well. However, if you are really flooding it on, you may have some **Gray Sealer** drip down to the surface below. If you drip on new fabric, clean it off with some MEK on a rag or it may show through the paint later.

**Don't leave any dry areas or places where the surface doesn't look translucent when you're through brushing.** This would mean the weave isn't sufficiently filled, and it leads to big problems with pinholes later. We'll talk about pinholes further on.

The idea is to brush on a wet coat, and then make only one more pass with the brush to level any small bubbles that may have formed. Look at the wet surface glare area to check for bubbles.

**Work fast, quit brushing, and get your brush out of there before the Gray Sealer dries.**

**Gray Sealer dries in about 15 minutes.** In hot weather, it can dry in as little as *5 minutes!* You have to brush it on and quit fiddling with it. If you continue to brush while it's drying, you can leave serious brush marks.

*"Can't I spray on this first coat of Gray Sealer?"*

We don't recommend it. Brushing does a much better job of filling the weave. If you don't fill the weave sufficiently, you get pinholes later.

Brush marks are not a problem if you follow the instructions above.

*"Can't I just sand the drips or flaws in Gray Sealer?"*

Nope. There is not enough **Gray Sealer** on there yet to sand. You will have plenty of opportunities to sand later in the process.

---

## Rib Lacing

---

Fabric on wings needs to be mechanically secured to the ribs rather than just cemented. The standard mechanical attachments are: rib lacing, PK screws, pop rivets, and fabric clips.

**On certified aircraft,** the method you use to secure the wing fabric to the wing ribs should be the same one used at the factory when your airplane was manufactured. If you want to use a different method, you have to get a field approval from an FAA Field Service District Office.

On some aircraft, the tail feathers and occasionally some fuselages were rib laced. Again, replicate the way the factory did it.

Using cement alone is a recent idea that came out of the ultralight movement. The theory was that since the speeds and wing loadings were low, you didn't need mechanical attachments. However, many kit planes have evolved from enclosed ultralights to high-horsepower fire-breathers. Some have 180 HP! **They need to be rib laced!** Additionally, any ultralight or very light aircraft you plan on keeping for more than just a couple of years needs **RIB LACING.**

Incidentally, we call it rib *lacing* rather than rib *stitching* because we are lacing around the whole rib, not just stitching it to the top or bottom rib caps.

Aircraft fabric cement is made for shear loads, not peel. But in flight, an aircraft is subjected to constant peel loads from the center of lift on the top of the wing. The giant vacuum cleaner called lift is always trying to peel your wing fabric off the top surface.

Aircraft fabric cements were never designed to resist this peel force, certainly not for the long service lives fabric covering jobs can last.

## 5 - Let's Do a Wing!

---

If you're covering an experimental aircraft for which there is no rule or precedent, **WE STRONGLY RECOMMEND RIB LACING OR SOME OTHER MECHANICAL ATTACHMENT.** Fabric cements were never meant to be the sole means of attaching fabric to ribs, even to 1" ribs.

---



---

**Propwash area includes all the wing ribs included within the diameter of the propeller, plus one more rib.**

---

### Using the Chart

We'll use our J-3 Cub as an example. Position the wing right side up. We'll mark the top of the wing first.

### How Far Between the Laces?

Let's start with how to plan and lay out rib lace spacing. This works for screws and rivets, too.

Take a look at this chart:

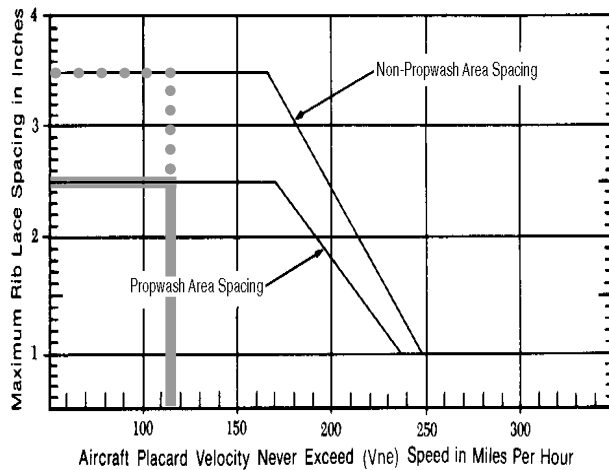

This same chart is also in the FAA's AC 43.13, and should be used if you don't know the rib lace spacing of your aircraft as it was manufactured.

The bottom of the chart shows the placard maximum speed of aircraft in miles per hour. The left side shows the distance between laces (or screws or rivets).

Notice that there are two lines, one for spacing in the propwash areas, and another for spacing in other than propwash areas.



---

**The chart gives us two sets of spacing, but you don't really have to lay out two sets of laces if you choose not to.**

---

Remember, the spacing you get from the chart is the **MAXIMUM** spacing between laces. Since

## 5 - Let's Do a Wing!

there is no restriction on using narrower spacing than the maximum, it's just as easy on most airplanes to use the propwash spacing ( $2\frac{1}{2}$ " for the whole wing. It looks neater, it's easier to lay out, and you'll only end up doing a few more laces in the bargain.

**So in our discussion on how to measure and layout the laces, we'll go with  $2\frac{1}{2}$ " laces for the whole wing.**

**Tailfeather Spacing:** If your aircraft requires you to lace the tailfeathers, and you don't know the original spacing, use twice the wing propwash spacing.

### Marking Rib Lace Locations

Now that you know the spacing, you'll **measure, lay out, and mark** the position of the individual rib laces. This will result in evenly spaced, neat looking laces. Once you mark the lace positions, you'll pre-punch the lacing holes with a needle to give you guides to lace through. Not only does this give you a good-looking job, but saves lots of time by not having to measure while lacing. Pre-punched holes save lots of fumbling.



Put the wing **top side up** on the sawhorses. Get a ruler or a tape measure and a soft lead pencil.



**Remember, no pens or magic markers. They will bleed all the way through your paint.**

**You begin measuring rib lace spacing at the butt rib**, working from aft edge of the leading edge fairing, where it meets open fabric, toward the trailing edge. **The first rib lace is always placed at half the required distance of the others.** Since our required distance is  $2\frac{1}{2}$ ", half of that is  $1\frac{1}{4}$ ".

- Place the tape on the top of the butt rib and start measuring and marking. The first mark

goes  $1\frac{1}{4}$ " back from the leading edge fairing (half the chart distance). The next mark goes  $2\frac{1}{2}$ " beyond that. Keep marking in  $2\frac{1}{2}$ " segments all the way to the trailing edge. Make sure the last mark is no greater than  $2\frac{1}{2}$ " from the trailing edge.



- Now lay the measuring tape on the rib closest to the tip bow and do the same thing. Then, to be safe, pick a rib in the middle of the wing and do it again.
- Get the chalk line out and line up the marks made on all three ribs. Snap lines on the top of the wing. You should have parallel lines every  $2\frac{1}{2}$ " spanwise on the wing.

Every place the chalk line intersects a rib is where the rib lace will be. This is a nifty way to get nice even laces at the required spacing.

**Rib laces go through the entire wing and must be parallel to the spar face;** or in other words they should go straight up and down and all be parallel if you looked at them in cross section inside the wing.

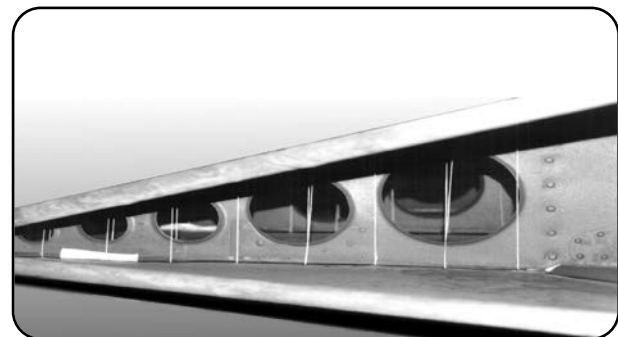

## 5 - Let's Do a Wing!

**The bottom surface is different.** If your wing was symmetrical, you could flip it over and measure and chalk the bottom as you did the top. The resulting laces would all be straight up and down and parallel. But most wings have an airfoil shape; that is, the top surface has a greater curve than the bottom surface, which is almost flat. Therefore, the top surface is longer than the bottom. So, if you measured the bottom exactly as you did the top of the airfoil, the resulting rib laces would certainly not be straight up and down and parallel. In fact, they would look like a sunburst! Not to worry.

### The Magic Template

You can keep the laces straight up and parallel by making a simple cardboard template.

- Hold a piece of cardboard up to the butt rib and trace the shape of the rib. **Also mark on it the position of the main (forward) spar.** Cut out the shape of the butt rib to make a template. Put the template against the butt rib and transfer to the template the spacing marks on **the top** of the butt rib.

- Lay the template on something flat. At each lace position along the top of the airfoil, draw



a line parallel to the main spar face, extending down through the bottom of the airfoil template. This gives you the proper positions for the rib laces on the bottom.

- Now transfer these lace positions, both top and bottom, to the other side of the template. This gives you a template for both wings.

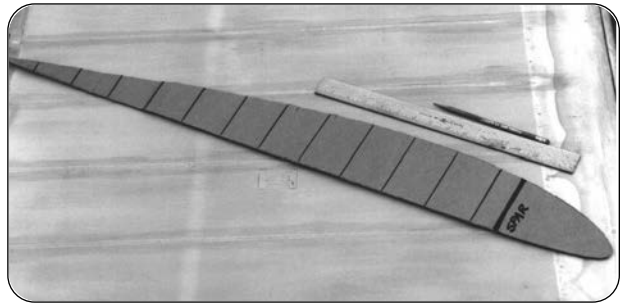

- Place the template back on the butt rib and transfer the marks from the bottom of the template to the bottom of the butt rib.

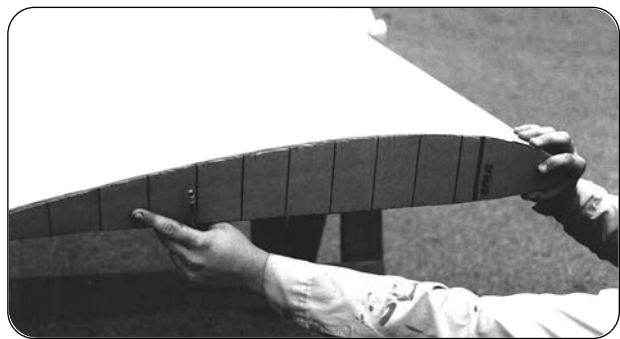

**Turn the wing bottom side up.**

- Use the bottom edge of the template to mark the lace positions onto a middle and outboard bottom rib. Snap your chalk lines as before, and you are done. All the rib lacing locations are marked.

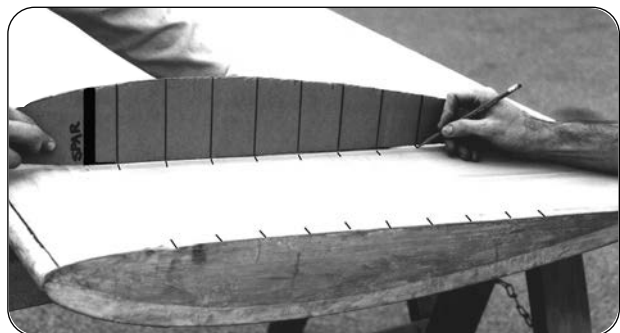

## 5 - Let's Do a Wing!



If you absolutely want to have both in-propwash spacing and out-of-propwash lace spacings, just make two templates. Use them as above.

### Reinforcing Tape

Reinforcing tape is an adhesive-backed polyester twill material that is stuck to the fabric over the rib cap **before** rib lacing. It reinforces the fabric so that rib laces, screws, or rivets don't cut right through the fabric when mechanical attachments are snugged down.

**Ceconite reinforcing tape** comes in  $\frac{1}{4}$ ",  $\frac{3}{8}$ ", and  $\frac{1}{2}$ " widths. Use the width of tape that exactly matches the width of your rib cap. Tape that is too wide will leave puckers when the laces are snugged down. Tape that is too narrow will allow fabric cuts where the reinforcing tape ends. Use two parallel  $\frac{1}{2}$ " tapes to cover a 1" rib.

- Simply peel off the paper backing and press the tape into position over the bottom ribs. Align the tape precisely with each rib cap. Extend the tape a minimum of 1" beyond the first and last laces on each rib. For cosmetics, it looks better to extend the reinforcing tape all the way to the leading and trailing edges of the wing.



**Position the wing right side up on the sawhorses.**

- Apply reinforcing tape along the top rib caps, just as you did for the bottom rib caps.

**Take care when cutting reinforcing tape. Uneven cuts will show through. Keep everything nice and square.**



**CAUTION: Don't use anything but genuine Ceconite polyester twill reinforcing tape. Substituting**

**fiberglass strapping tape or any other tape is not approved. Strapping tape fails easily in shear and falls apart in a few years. Rib laces can fail if you use strapping tape! It also negates your STC.**

- Once all the reinforcing tape is in place, pre-punch the top rib lace holes with a **rib lacing needle**. Punch holes where the chalk lines intersect the ribs, as close to the rib caps and tape as you can.

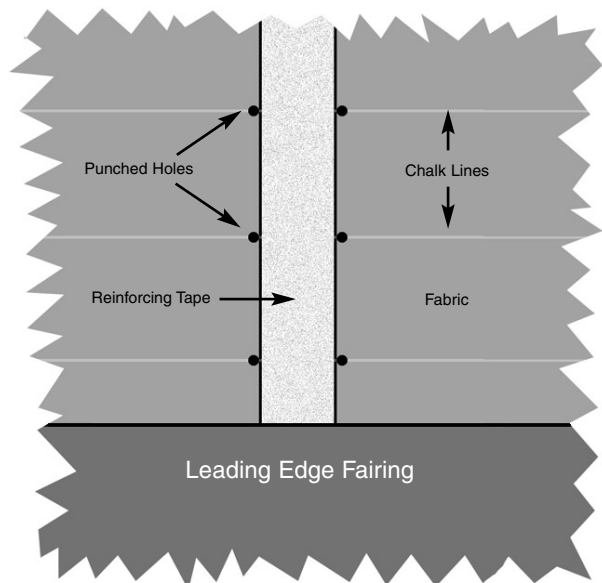

**Turn the wing over again, upside down on the sawhorses.**

- Pre-punch the holes on the bottom of the wing, same as on the top.

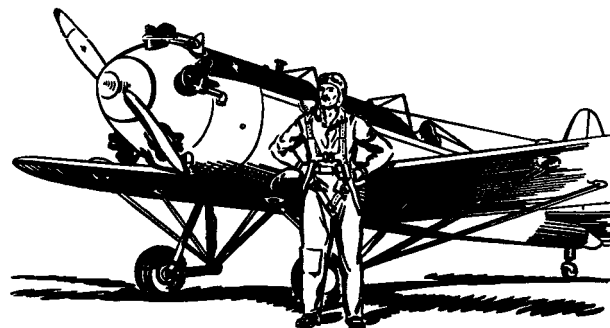

### Let's Tie Some Knots!

#### Rib Lacing Cords

There are two kinds of **Ceconite** polyester rib lacing cords, round and flat. It's your choice.

**Flat rib lacing cord**, like a shoelace, takes some untwisting at times. **Round cord** is faster and only slightly thicker than flat. Rib lacing cord is impregnated with a special wax.

#### Only three knots are approved with the Ceconite STC:

- 1. The Starter Knot.** This handy knot is used when you start a sequence of rib lacing. It's simply a square knot with a half-hitch on each side. It can also be used as a single lace in places where you cannot tie continuous seine knots. Use a **12" or 18" curved-tip needle** for this one. If you have a lot of time, you could lace your entire airplane with starter knots.
  - 2. The Modified Seine Knot** as shown in AC 43.13. After tying, this old standby stays on the exterior surface. The cord that runs between knots (the continuous cord) also runs on the surface. Leaves a lot of drag on the outside of the wing, but that's the way it was done from WWI on. **This knot isn't described here.**
  - 3. The Hidden Modified Seine Knot.** We recommend and will show you this knot. This "hidden" knot ends up on the inside of the wing; so does the continuous cord. So all you see with this knot is one small lace across the rib; much cleaner. You'll need a **curved-tip needle** to tie this knot.
- You can rib lace with the wing on sawhorses and spend a lot of time exercising your knees, or you can put the wing in a vertical stand and pass the needle back and forth with a helper.

- Wings can be laced while positioned horizontally or vertically, usually leading edge down. Exceptionally wide-chord wings are easier to lace when positioned vertically, with the needle returned by a helper.
- You can start at the leading edge and work aft, or vice versa. You can begin on either the top of the wing or the bottom. It doesn't matter because all the knots will be concealed inside the wing.
- To save time untangling long lengths of rib cord and prevent wearing off the wax coating and fraying the cord by pulling through the fabric too many times, use shorter lengths of rib lacing cord. Six to eight feet is plenty, depending on the rib thickness. Tie off the last knot in each length with a half-hitch.

---

**Make sure all cables are temporarily secured taut in their normal runs. If you rib lace with them in a loose condition, they could destroy adjacent rib laces when you pull them back to their normal runs as you assemble the airplane.**

---



- Set up a light so it shines through the wing to reveal the structure and obstacles within.
- Thread a **curved-tip needle** with about six feet of cord.

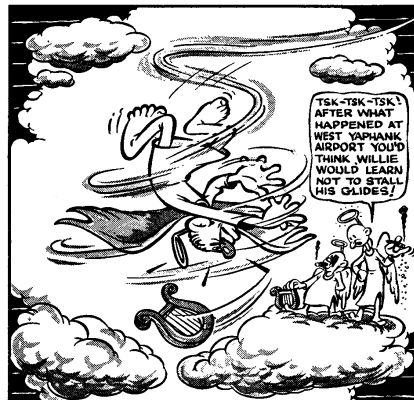

## 5 - Let's Do a Wing!

### Before You Begin Any Knot...

1. Start by inserting the threaded needle into the prepunched hole on the right side of the reinforcing tape. Guide the needle through the wing and out the bottom prepunched hole directly below the top hole.

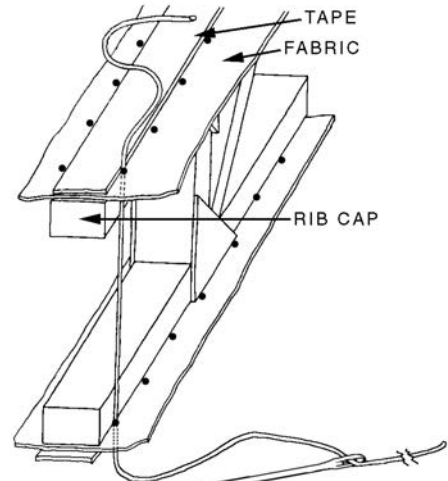

2. Leaving a tail of thread on the top of the wing, pull the needle out the bottom. Cross to the left of the bottom reinforcing tape, insert the needle into the prepunched hole on the left side of the tape. Push the needle and thread all the way back up inside the wing and out through the prepunched hole on the left side of the top reinforcing tape.

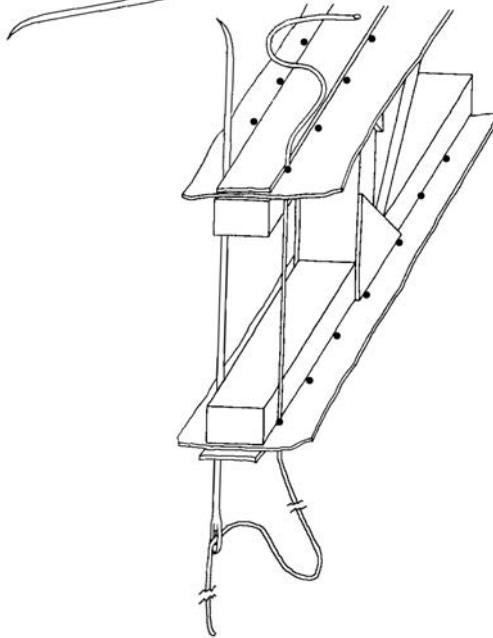

3. Pull the needle out with thread attached, but don't pull all of the thread out. You will have a short end of the thread (about 4 to 5 inches) on the right side of the top reinforcing tape and a lace of thread running from the top through to the bottom on the right of the rib and back up to the top on the left as illustrated.

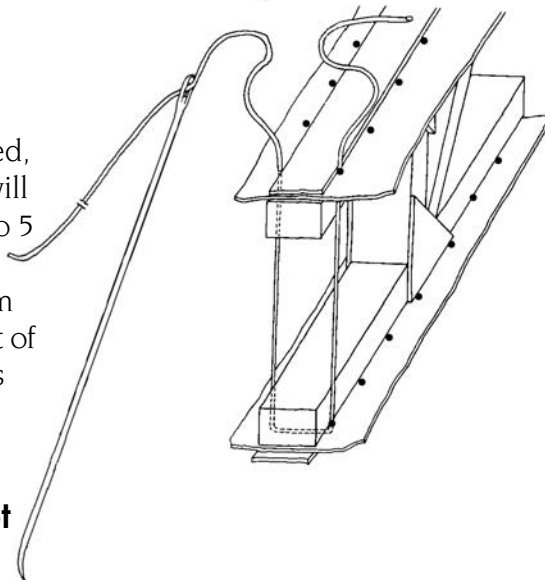

**Now you're ready to tie a Starter Knot**

## 5 - Let's Do a Wing!

### How to Tie a Starter Knot

1. Tie a square knot by passing the short end of the cord through the folded-back loop.

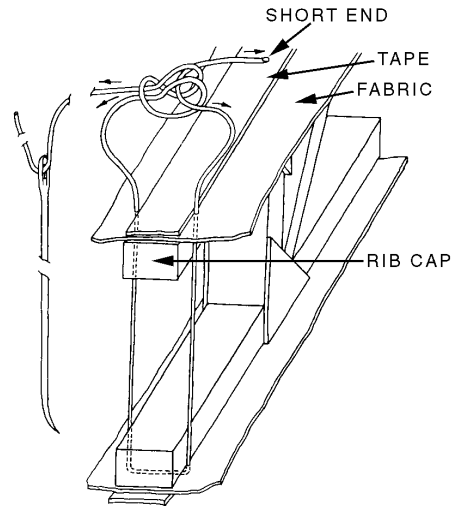

2. Lock the tightened square knot with a half-hitch on each side.

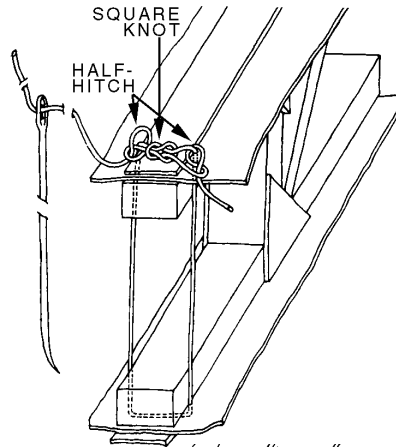

3. Route the needle back through the starting hole. Bring it back out through the next hole aft on the same side of the rib cap. Pull the **starter knot** inside the wing.

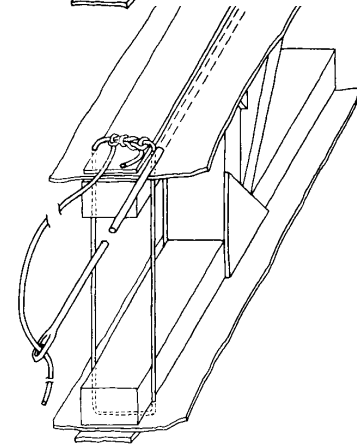

- When you're all done, it should look like this After tying the Starter Knot, you're ready to tie a **Hidden Modified Seine Knot**.

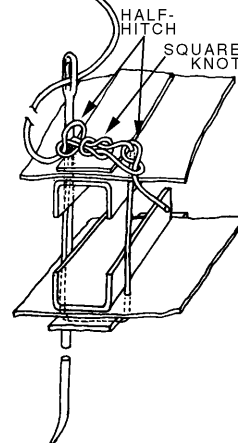



---

## How to Tie a Hidden Modified Seine Knot

---

1. Route the needle back in through this same exit hole, and then out again through the corresponding hole on the opposite wing surface. Leave about a 3" loop on top when the needle is pulled clear.

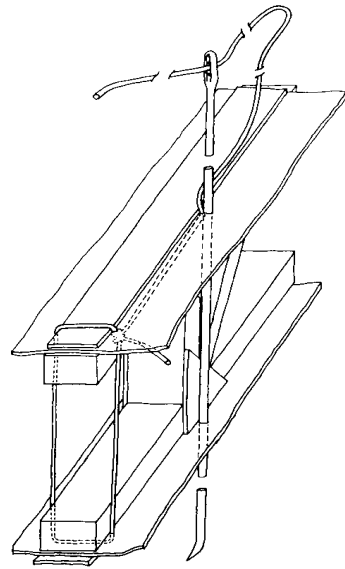

2. Cross under the rib cap, and return the needle. As the needle emerges, orient the loop as shown and pass the needle up through it.

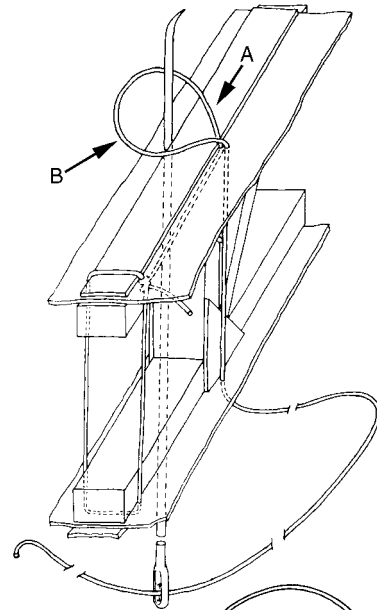

3. Pull the needle clear. Use the tip of the needle to reach under part B of the loop, hook part A, and pull it toward your starting point.

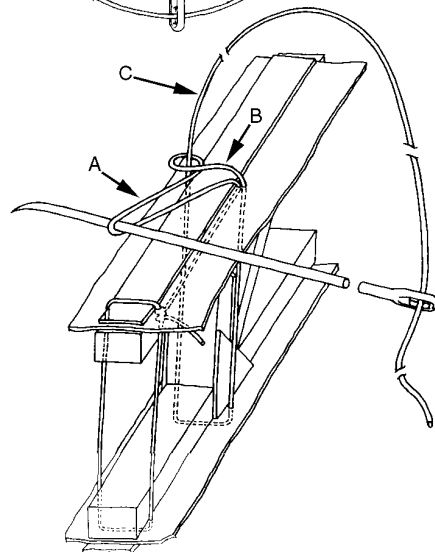

## 5 - Let's Do a Wing!

4. Rotate the needle clockwise, twisting the captured part A. Route the needle tip over part A, then under part B.

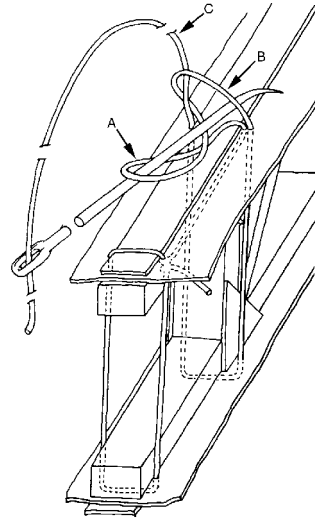

5. Now pass the needle over cord part C and pull it through. Hold part C perpendicular to the fabric while you pull, to keep the cord from getting tangled.

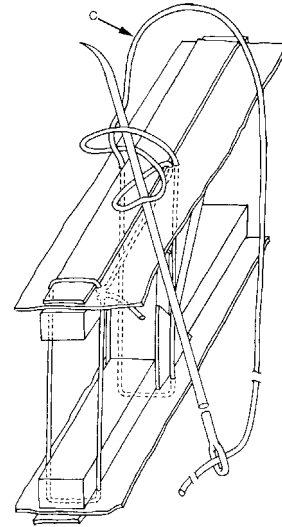

6. Pull part C perpendicular to the fabric to remove all slack in the lacing cord back to the last rib lacing knot, while working the loose knot over to the right side. Do not pull on part D.

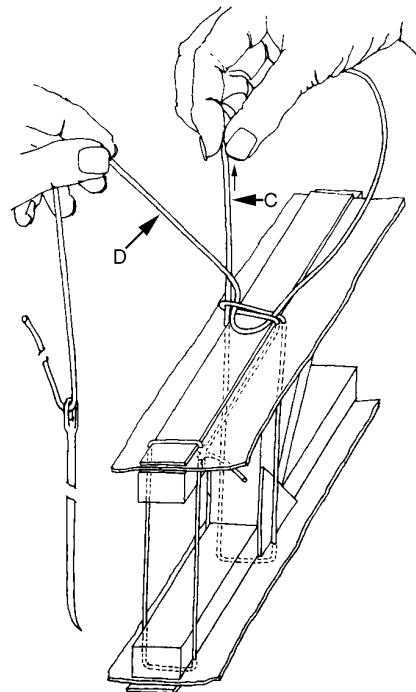

## 5 - Let's Do a Wing!

7. With all slack removed by pulling part C, hold the loosely formed knot with your thumbnail. Pull firmly on part D, perpendicular to the fabric surface, to secure the finished knot. This is the end of the first modified seine knot.

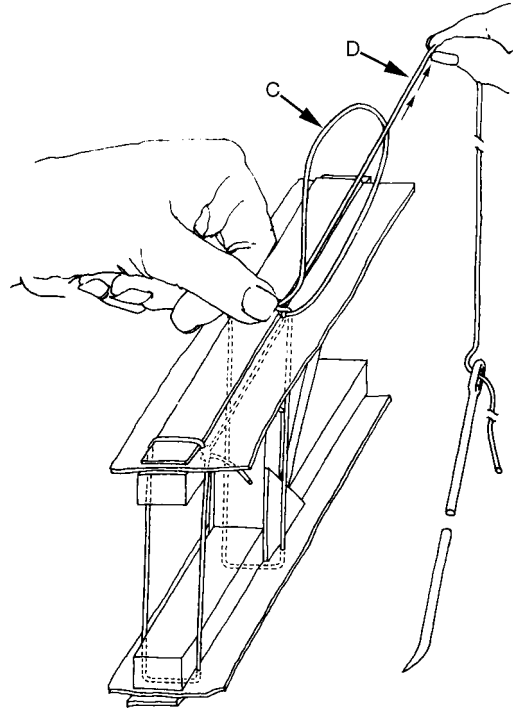

Now continue by routing the needle back through the same hole that you started the last completed Hidden Modified Seine Knot, under the fabric along side of the rib, and out of the next marked hole to start another Modified Seine Knot. Continue tying Modified Seine Knots at each marked location on the rib until you've either completed the entire rib or you've come to the end of your length of lacing cord. In either of these cases, then go to Step 8 below.

8. After completing an entire rib, tie off the last modified seine knot with a half-hitch.

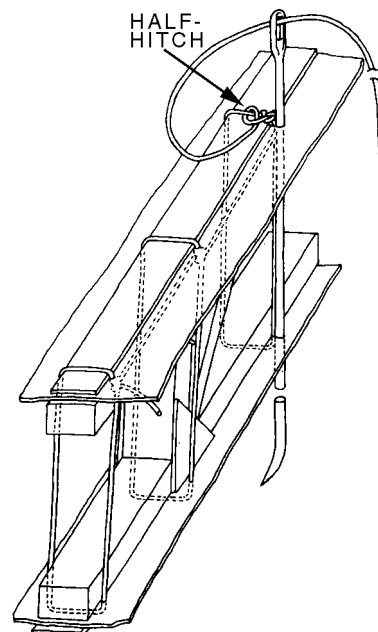

---

**If you run out of cord halfway through the rib, tie it off with a half-hitch and start again at the next set of holes with a starter knot and more cord.**

---

---

## What If You Can't Get Through the Entire Wing to Rib Lace Normally?

---

Sometimes hidden structures, fuel tanks, etc. may be in the way and make it impossible to lace around the whole rib.

In this case, **you can lace to just the cap**. Use a **curved needle** to tie a single starter knot.

1. Go in on one side of the rib cap, and come out on the other.

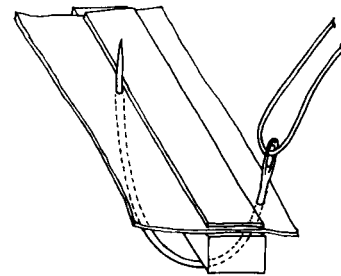

2. Go back in through the exit hole, then come out opposite the first entry hole.

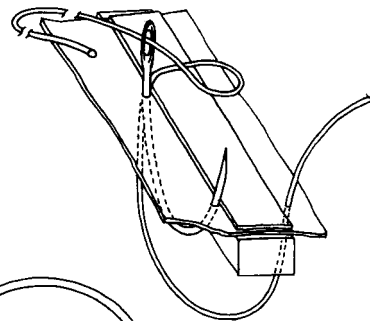

3. Now you can tie a starter knot.

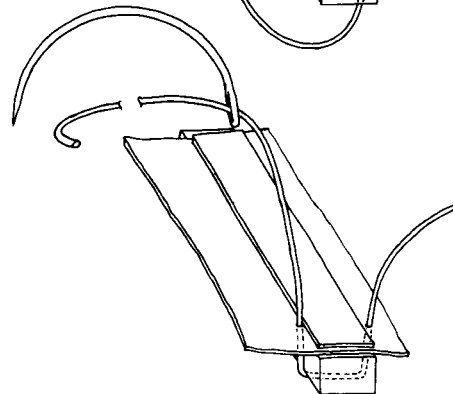

## 5 - Let's Do a Wing!

---

### Other Mechanical Attachments:

---

#### Pop Rivets

Fabric pop rivets are special broad head rivets sold by aircraft supply houses specifically for use on metal ribs. **DO NOT attempt to use the hardware store variety!**

Start with the reinforcing tape, as with rib lacing, and use the same spacing. If an existing rivet hole is wallowed out or damaged, drill a new hole half an inch or so away. For best results use a 1/2" diameter .016" aluminum washer under each rivet. Plastic washers tend to crack and fail with age.

Pop rivets are easy to install, but they're a real pain to drill out at re-covering time.

#### PK Screws

These are small self-tapping stainless steel sheet metal screws. You'll find them in a variety of certified aircraft that have metal ribs.

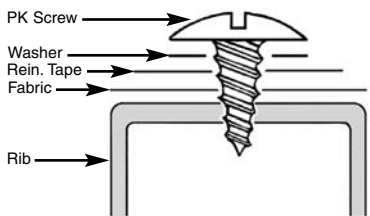

As with the pop rivets, start with the reinforcing tape and use the standard spacing. If an existing screw hole is wallowed out or damaged, drill a new one half an inch or so away. For best results use a 1/2" diameter .016" aluminum washer under each PK screw.

Don't use PK screws on wooden ribs. They can create a path that introduces moisture into the rib over the years.

#### Fabric Clips

Fabric clips are pieces of wire formed into a row of self-locking "barbs" that snap into holes or slots in metal ribs. Taylorcraft and Cessna use them, and they're available from your favorite supply house.

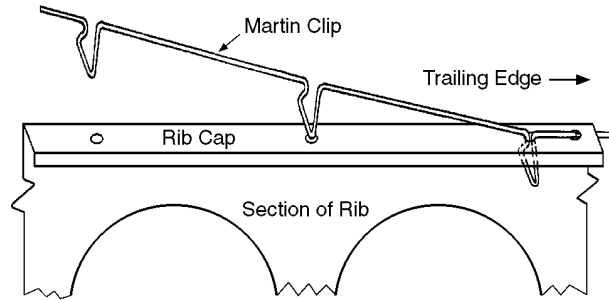

Clips are the hardest on ribs, particularly if someone tries to yank off the old fabric while the clips are still in place. This can easily ruin an entire set of ribs. And because the spacing of the barbs is unchangeable, you can't just drill a new hole to replace one that's damaged. If you need to use clips, find out all you can about your particular clip system before you make an expensive mistake.

---

### Finishing Up

---

When you are finished rib lacing or installing mechanical attachments, you need to clean the ribs of all wax and fingerprints, and fill the reinforcing tapes with **Gray Sealer**.

- Use some **Gray Sealer Reducer** on a clean rag to remove the excess wax that balled up around the rib laces. It does.
- Get out your **Gray Sealer** can and a narrow brush. Brush **Gray Sealer** into the reinforcing tapes until they soak up enough to turn them gray and fill them up entirely. It usually takes at least four coats to fill them. A 2" brush held sideways works nicely for this job. Be careful about brush marks or ridges that may form at the sides of the brushed area. Feather out ridges before they dry.



**It's important to fill reinforcing tapes with Gray Sealer. If you don't, they'll act like sponges under finishing tapes, robbing the finishing tapes of the Gray Sealer they need for good adhesion.**

## 5 - Let's Do a Wing!

### Inspection Hole Reinforcements

It's obvious that you'll need access to parts of your airframe once covered. Pulleys, bellcranks, brake master cylinders, and places that require frequent inspection all need to be accessible. You certainly don't want to omit this step and then have to cut into your nice new paint job later on.

You need to have a good idea of where these access holes need to be. Studying the old covering before removal is one way, or you could look at a covered airplane like your own and make a "map" of where you need to put the access holes. Shining a strong light through the translucent fabric helps, too. Access holes are usually put on the underside of the wings and fuselage. By the way, it's hard to have too many access holes. Over the years, you'll regret the ones you decide to leave off.

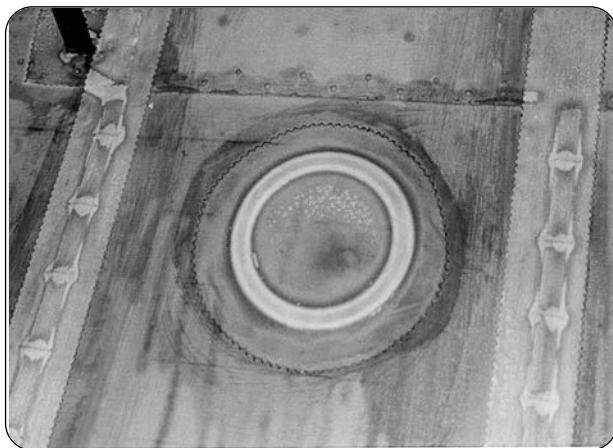

Easy access can be achieved through reinforced holes in the fabric, each with a removable cover. CAB plastic reinforcing rings (also called inspection rings) are available from our distributors. They're a standard size, 3 $\frac{1}{16}$ " ID. This is big enough to get your hand through. The aluminum inspection hole covers that snap over them are also available from our distributors.

Once you've figured out where the access holes should be located, they are simple to install.

- Cement the rings directly onto the fabric with straight **Star-Tak** cement. Clean up any cement that drips or oozes with MEK.



**Don't cut the centers out of the holes until the airplane is finished and painted. Even then, don't cut them out until you need access. Some may never need to be cut.**

To make sure the rings stay on, you'll apply a "doily," a circular piece of fabric, over each one with **Gray Sealer**.

- Make a simple frame of scrap wood, about 3' by 3' square.
- Cement or staple some **Ceconite Uncertified Light** fabric to the frame.
- Tighten the fabric on the frame at **250°**.
- Take the fabric off the frame, and draw 6 $\frac{1}{2}$ " circles on the fabric with a soft lead pencil. Gallon cans are good patterns.
- Carefully cut out the doilies with pinking shears.

This pre-shrunk **Uncertified Light** fabric makes beautiful smooth doilies that will mold easily around the reinforcing rings. If you use thicker scrap fabric that is wrinkled to begin with, it'll look terrible when applied, and you'll have to spend an inordinate amount of time smoothing out the wrinkles.



**Ceconite style Uncertified Light fabric works great for doilies. Ceconite 102 is OK, too, but doesn't mold as tightly.**

## 5 – Let's Do a Wing!

- Pre-coat the area where the doily will be applied with two coats of **Gray Sealer**. Feather out the edges of the **Gray Sealer** to prevent brush marks.
- Apply each doily by brushing a wet circle of **Gray Sealer** inside and outside the ring, big enough to wet out the doily. Lay the doily over the ring. With a dry brush (meaning not much **Gray Sealer** on it), work the doily into the wet area. The best bond is achieved when the wet **Gray Sealer** soaks upward into the weave of the doily fabric.
- When the **Gray Sealer** dries, brush another coat over it. Be careful not to leave brush marks or ridges.

By the way, buy about twice the number of aluminum reinforcing hole covers you need. When you paint your airplane, lay out all the covers and paint them, too. Store those you don't immediately use. You'll appreciate having a bunch of spares already painted in future years.

---

### Finishing Tapes and Gussets

---

Finishing tapes are simply pre-cut strips of **Ceconite** fabric. These tapes are used to cover cemented or sewn seams, or to provide an extra layer of cloth over areas that need reinforcement. **Ceconite** tapes come in two styles, pinked which are cut in a zig-zag pattern, and straight.

*“Which are better? Straight or pinked?”*

OK, let's set the record straight. During WWI, the edges of aircraft tapes were unravelled by hand to leave a crude fringe. The idea was to give a nice transition from fabric to threads to promote adhesion when they were doped in place. But unravelling the edges of the tapes was a real pain and it took a lot of time.

So they got smarter and figured that if tapes were cut with pinked edges, you get the same good adhesion with less labor. Pinking also kept the cotton from unravelling. So pinked tapes came into vogue in the twenties.

Straight-edge tapes came only with the introduction of polyester fabrics. Since polyester could be heat slit, it was an easy way to make a tape.

The problem with straight-edge polyester tapes is the ridge formed at the edge when they're heat slit. That ridge gives no transition to the tape and, in fact, promotes peeling over the years.

Pinked tapes have 41% more edge area to help adhesion. They're cut with a knife that leaves no ridge and, by golly, they are historically correct.

So we recommend that you use pinked tapes whenever possible!

### Kinds of Tapes

**WEIGHT:** Tapes come in two weights, **Ceconite Light** and **Ceconite 102**, our medium-weight tape. Both light- and medium-weight tapes are legal to use interchangeably over any of the **Ceconite** fabrics.

Light-weight tapes are easier to bend around corners. They also mold down to the surface more readily than do medium weights. **102** medium-weight tapes have more body and are appropriate for working airplanes or those that will see a lot of snow or ice.

**CUT ANGLE:** There are straight-cut and bias-cut tapes. Straight tapes are self explanatory. They are long, straight strips of fabric. Some catalogs call them linear. Bias tapes are cut from long tubes of sewn fabric. The weave of a bias tape is aligned at 45° from the edge. If you pull the bias tape, it gets narrower, like the old Chinese finger puzzle, and forms itself perfectly around

## 5 - Let's Do a Wing!

curves with no wrinkles. Bias tapes are used ONLY to go around curves like on rudders or wingtip bows.

**WIDTH:** Tapes come in a variety of widths, all with different uses.

### Straight Tapes -

- ◆ 2" tapes are the standard width for ribs and longerons. You can use 2" tapes legally on the whole airplane, but it looks pretty strange. Anyway, you'll use a lot of 2".
- ◆ 1" tapes are used for narrow fuselage stringers.
- ◆ 3" tapes are used for leading or trailing edges of wings and tail feathers.
- ◆ 4 or 6" tapes are used for leading edges of wings.

**Bias Tapes -** This is tricky; when you pull a bias tape around a curve, it gets about 1/3 narrower.

- ◆ A 3" bias will pull to 2" wide when applied.
- ◆ A 4" bias will pull to slightly less than 3".



**DO NOT ATTACH TAPES WITH Star-Tak! Star-Tak dries too brittle for a flexible bond on tapes. Tapes should be attached only with Gray Sealer thinned three to one with Gray Sealer Reducer.**

## Let's Tape!

**Tapes are applied in this order:**

1. Fabric gussets.
2. Tapes that are oriented CHORD-WISE, into the slipstream (like tapes over ribs).
3. Tapes that are oriented SPAN-WISE, across the slipstream. (like leading edge tapes).

### The Three Basic Steps in All Taping

1. Precoat the fabric where the tape will be with two coats of **Gray Sealer** thinned three to one with **Gray Sealer Reducer**. Let it dry. **Remember! Two Coats!**
2. Install the tape with a very wet coat of three-to-one **Gray Sealer**. Let it dry.
3. Brush a final coat of **Gray Sealer** over the dry tape.

**Make sure you feather out any ridges or built-up edges of Gray Sealer. While still wet, brush them out quickly, being careful not to leave any brush marks. All ridges and brush marks will always show.**



### Fabric Gussets

A fabric gusset is simply a piece of pre-shrunk fabric cut to shape to fit over any oddly shaped place you want to reinforce.

An example would be a gusset cut to fit over a strut fitting protrusion. This gusset would have a neat hole trimmed exactly to go over the end of the protrusion. The gusset, however, would be big enough to cover the elongated hole left in the wing fabric after heat tightening around the base of the protrusion.

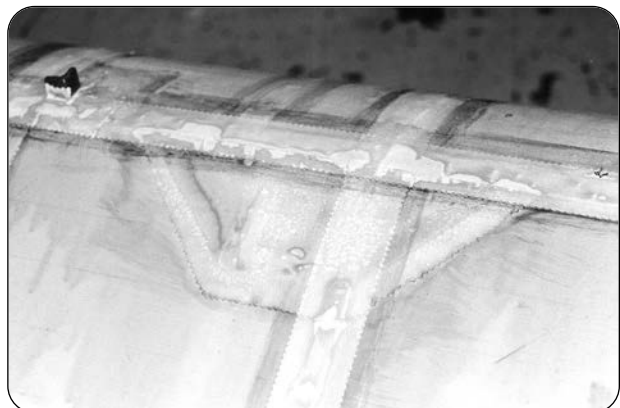



## 5 - Let's Do a Wing!

Or you might cut a custom shaped gusset to cover an odd-shaped hard panel underlying the fabric. Gussets are sometimes easier to cut than trying to make tapes work over odd shapes.

Remember the previous section on installing reinforcing rings? Smooth, professional gussets are cut from pre-shrunk Uncertified Light fabric exactly like inspection ring doilies.

- Hold the pre-shrunk fabric over the area you want the finished gusset to cover. Trace the shape with a soft lead pencil and a straight edge. Oversize the gusset at least  $\frac{3}{8}$ " around its perimeter.



**A gusset or tape used to reinforce a hard surface underneath fabric needs to have at least 3/8" extending past the edge of the hard surface onto the adjacent fabric. After all, the reason to put a tape or gusset over the hard surface is to keep the edges of the hard surface from chafing through the fabric. You need at least 3/8" of fabric overlap for a good Gray Sealer bond.**

- Trim with pinking shears and attach with **Gray Sealer**, as you did with the doilies.
- Pre-coat the fabric with two coats of **Gray Sealer**, and let it dry.
- Brush a wet coat of **Gray Sealer** and lay the gusset into it. Work out bubbles with a dry brush.

### Chord-wise Tapes

**Let's put on the tapes over wing ribs.**

- Get out the **Gray Sealer** bucket and fill it with **Gray Sealer** thinned three to one. You will use only a 2" brush for taping.

**Pre-coating - the hidden secret to adhesion.**

Before you lay any tapes, make sure you brush

two coats of **Gray Sealer** over the area where the tape will go. This pre-coating insures that there will be enough dope to give a good stable bond between the tape and the fabric. Use a 2" brush. Make sure you don't leave a ridge of **Gray Sealer** at the edges.

- For a first-class job, draw lines with a pencil and straight edge in the areas where the tapes are to be applied. This not only gives you a reference line to tape to, but a guide for putting down a neat pre-coat of **Gray Sealer**.

**You have two options when trimming and applying rib tapes.**

1. You can use **one tape** long enough to wrap around the whole wing, top and bottom.
2. Or you can cut **separate bottom and top tapes** and butt them together at the leading edge.

**Let's do one of each.**

### One-piece Rib Tape

- Cut a 2" tape long enough to hang over the trailing edge an inch or so, wrap around the whole wing, and have some extra extending past the bottom trailing edge.

The plan is to attach the tape to the top of the wing first. At the leading edge, roll up the excess tape and clip it with a clothespin to keep it off the ground. Later, when you turn the wing over, you'll unroll the tape and **Gray Sealer** it to the bottom.

- To apply the tape, brush a very wet stripe of **Gray Sealer** over the area we previously pre-coated. It helps to have those straight pencil lines as a guide.

Don't skimp on the **Gray Sealer**. You have to work fast, yet get a lot on. If you're working by yourself, you might consider giving yourself more

## 5 - Let's Do a Wing!

time by brushing only as far as you can reach and apply the tape in stages. Most of the time, however, you should be able to do the whole top section of the tape if you work fast.

- Lay the tape into the wet stripe of **Gray Sealer**. It should immediately soak up into the tape. Wipe the brush dry and use it as a tool to press the tape into the stripe of **Gray Sealer**. The dry brush can also be used to work out any big bubbles. Work fast and get the brush out of there before the **Gray Sealer** starts to dry. If you fiddle with it too long, you'll leave noticeable brush marks.

*"OH NO! There are bubbles around the rib laces! I can't get all the air out! It didn't form down over those areas! Before I could work them all out, the Gray Sealer dried!"*

*Don't panic.* This is perfectly normal. What appear to be air bubbles over the rib laces (or rivets or screws) are really the natural fairing tendency of the tape as it angles off the protrusion of the lace. You'll never get all these faired areas perfectly cemented down in the **Gray Sealer**.

People go to great lengths to try to get these "bubbles" out, but to no avail. Don't worry about them. When the **Silver Urethane Fabric Primer** covers them later, you'll never know they were there.

**What is important is to make sure that you have at least 3/8" to 1/2" of the edge of each tape firmly wetted out and cemented with Gray Sealer. From the pinked edge in, the first 1/2" of the tape should look gray and well attached with no dry areas or voids.**

**You'll always have some wrinkles or bubbles in tapes when you apply them.** Don't worry, they will ALL come out later with heat from your iron.



---

**Don't fiddle around with small wrinkles or bubbles in the wet tapes. You're bound to leave brush marks. We'll fix them all later with the iron.**

---

As the **Gray Sealer** dries, it will no longer look uniformly gray under the tape. **Gray Sealer** dries with a mottled, splotchy look. Perfectly normal. If you started with a really wet layer of **Gray Sealer**, you did it right.

- As you did on the top, brush a very wet stripe of **Gray Sealer** onto the previously precoated areas, unroll the tapes, and apply them to the bottom of the wing.
- Also as with the top of the wing, lay the tape into the wet **Gray Sealer**. Use the brush to press the tape into the **Gray Sealer**. Work fast and get the brush out of there before the **Gray Sealer** starts to dry.

You may notice some wrinkles in the tape as it wraps around the leading edge. This is really quite apparent on tapered-wing aircraft. Again, don't fiddle with them now. The iron will smooth them out later.

### Two-piece Rib Tape

A two-piece tape is butted together at the leading edge.

- The easiest way to do this is to apply all the tapes on one side with a bit of overhang at the trailing and leading edges. A good guide for the overhang at the leading edge is your old wing center chalk line you used when you applied the wing fabric. Apply the tapes so they are cemented slightly past this line with about an inch of dry tape overhanging to use as a handle.
- Trim the tapes on the wing center chalk line with a fresh straight razor. Remember, hold the razor firmly on the line, and pull the tape

## 5 - Let's Do a Wing!

into the blade. Don't slice with the razor or you'll cut the fabric below!

- When you apply the tapes on the other side of the wing, trim them the same way. This neat butt seam will never show when the leading edge tape is placed over it.
- Trim the trailing edge tapes by cutting them off flush at the trailing edge when they are dry.
- After 30 minutes or so, when all the tapes are dry, brush another coat of three-to-one **Gray Sealer** over them. Watch out for brush marks, and be especially careful not to let noticeable edge build-ups of **Gray Sealer** occur. Feather out **Gray Sealer** edges with the brush before they dry.

### Span-wise Tapes

The long tapes over the leading edge, trailing edge and spars go on next. Here's a span-wise tape installed along a spar.

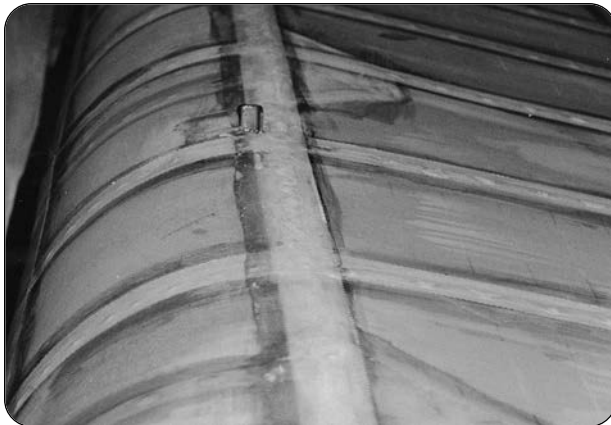

- First, smooth out all imperfections where the long tapes will lie with a **225° to 250° iron**. Glue lumps, fabric wrinkles, and other ugly spots will all iron out with enough patience and pressure from the tip of the iron. Don't get lazy here and decide that since another tape is applied over imperfections that they won't show. Trust me! They most assuredly will. Now is your chance to get them out!



---

**Long tapes should never be aligned by eye. Use a chalk line. Straight tapes are the trademarks of good workmanship.**

---

- Pre-coat and apply long tapes just like all others. Brush an additional coat over them when they're dry.

### Leading edge tapes are Gray Sealed to the wing in two operations.

- Precoat the leading edge with two coats of your thinned **Gray Sealer**, making a nice wet stripe that extends 2" above the center line and 2" below it. Your 4" finishing tape will be set into this stripe.
- When the **Gray Sealer** dries, snap a fresh chalk line along the leading edge, 2" above the center line.
- Brush more **Gray Sealer** only onto the area between the center line and your new upper chalk line. Leave the area below the center line dry. If you're working by yourself, do only 2 or 3 feet at a time. Don't rush. Remember, your friends are gonna sight down every one of your tapes!
- Align the upper edge of the tape with the new chalk line as you work it into the wet **Gray Sealer**.



## 5 - Let's Do a Wing!



**NEVER USE AN IRON HOTTER THAN 225° ON A TAPE! Tapes are raw fabric and are not pre-shrunk. If you so much as touch them at 250°, they will shrink about 5%. The end result will be a curved tape. Ugly!**

- When the entire upper half of the leading edge tape is attached and dry, heat-form the tape by rolling it around the leading edge with a **225° iron**, working the lower half into the **Gray Sealer** precoat.



- Apply a wet stripe of **Gray Sealer** to the lower leading edge. Work the tape you just heat formed into the **Gray Sealer** with a dry brush.
- Finally, brush another coat of 3-to-1 thinned **Gray Sealer** over the entire tape. Watch out for brush marks, and be especially careful not to let noticeable edge build-ups of **Gray Sealer** occur.

**The trailing edge tape is installed in the same manner, using a chalk line to keep it nice and straight.**

### Bias Tapes

Let's put a bias tape over the curved wingtip bow. We'll assume you used a 4" tape on the leading edge and a 3" tape on the trailing edge.

Remember, a bias tape shrinks about a third when it's pulled. So to plan professional join-ups with the leading and trailing edge tapes, do it this way.

Start by butting the leading edge 4" tape with a 4" bias tape. When we pull the bias, it'll shrink to about 3" to match the 3" trailing edge tape.

- Roll out enough bias tape to curve around the entire tip bow. Bias tapes have sewn seams about every 5 feet, so cut your tape off the roll right after a sewn seam to give you a full 5 feet before another seam appears. Lay the bias tape out on the workbench, and with a soft lead pencil draw an exact centerline along its entire length.

- Without pulling on the bias tape, apply **Gray Sealer** to the first 3" or so of the surface where the tape will meet the leading edge tape. Make this a careful butt seam.

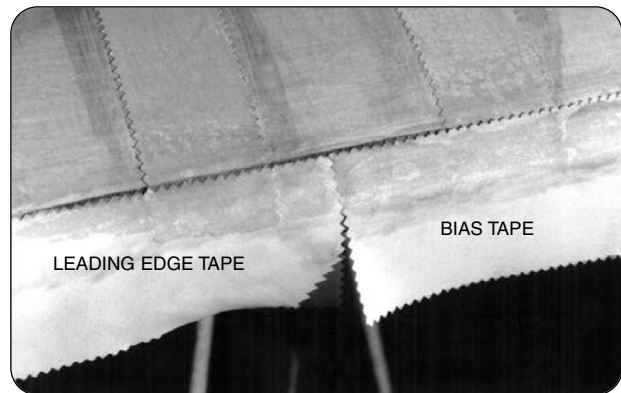

- Line up the pinked edges of both tapes on either the top or bottom of the butt seam, since it probably won't join perfectly on both top and bottom surfaces. Pick the side you want to be perfect. On high-wing airplanes it will probably be the bottom half, since that's the edge that always shows.

- Clamp the **Gray Sealed** area of the bias, or hold it with your fingers until the **Gray Sealer** sets and it stays in place. Roll the extra bias

## 5 - Let's Do a Wing!

up, or drape it over the wing while the first 3" dries.

When it's really dry (give it an hour to be safe), you are ready to pull the bias around the tip bow. Bias tapes need to be applied all at one time, you can't pull only short sections of the tape. So you'll have to work fast.

- Pre-coat with two coats as always. When dry, apply a really wet coat of **Gray Sealer** around the whole tip bow. Work fast, but be neat.
- Now pull the bias around the tip bow. This photo actually shows a bias tape being pulled around the top of a rudder, but the idea is exactly the same.

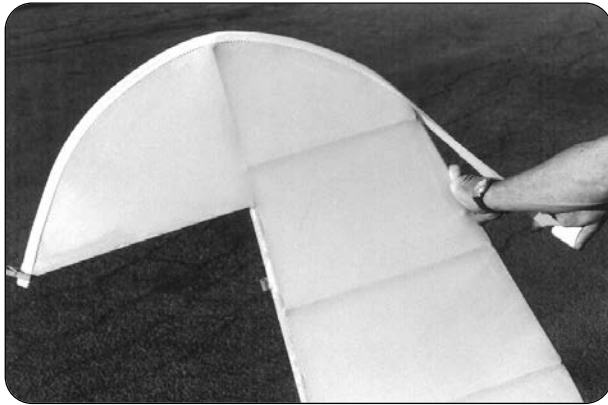

- Use the pencil centerline to keep the tape centered on the bow. Keep pulling until you have no wrinkles and the tape lies perfectly flush. If you let the pencil centerline slip up or down on the bow you'll have more tape on one side than the other.

The 4" bias should pull down to about 3" to match the trailing edge tape.

### Different Surfaces

When you attach tape to two different surface types, such as over fabric and a metal gas tank, use **Star-Tak** under the tape over the metal, and **Gray Sealer** under the tape over the fabric.

### Aircraft with Big-engine Modifications

If you are taping an aircraft with a big engine mod, you should consider some alternatives. Remember that the fabric on a 180-horse Super Cub is structurally not much different than a 65-horse J-3, and that fire-breathing Super Cub is going to create a whole lot more slipstream vibration than the J-3. Increased vibration can cause early paint cracking problems.

You can prevent early paint cracking by using wider tapes in the slipstream area or, in some cases, double taping.

If you have any questions about your specific hot rod, call us at the factory before you tape. We can give you some suggestions to prevent early paint cracking.

---

## Drain Grommets

---

Airplanes get water in them, and that water needs to get out. Rain and condensation can introduce significant moisture into a tube and rag airplane.



Each bay of a wing, tail feather, or fuselage must be allowed to drain. Look at the structure and think about where water will collect. Common sense will tell you where the drains should go. Put a drain hole at the lowest point of each collection bay on the bottom of the surface. Most wings, for instance, will have a drain next

## 5 - Let's Do a Wing!

to the outboard side of a rib at the trailing edge in each bay. Some wings have a drain hole on each side of the rib at the trailing edge.

Drain holes need to be at least  $\frac{1}{4}$ " in diameter. They are usually reinforced by cementing a drain grommet directly over the fabric then cutting or melting out a hole.

Use only **Star-Tak** cement when applying drain grommets.

You can make a mini-doily about 2" in diameter called a dollar patch and apply these over the drain grommets. Cut them out with pinking shears. This is a good idea in propwash areas. Melt out the center with a soldering iron when the dollar patch is dry over the drain grommet.

### Drain grommets come in three types:

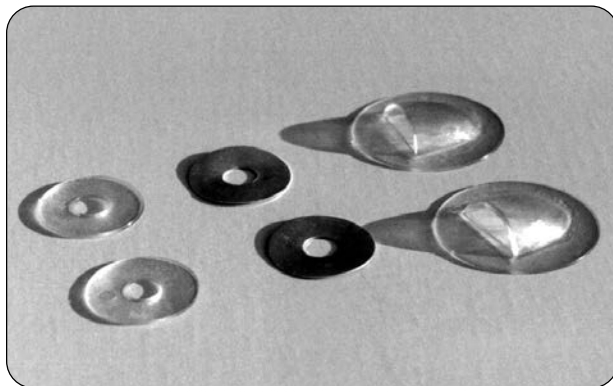

1. **Plastic grommets.** These glue well, but can get brittle over the years.
2. **Aluminum grommets.** These have the longest service life, but need dollar patches in propwash areas.
3. **Seaplane grommets.** These are plastic and have a little vented hood over them that helps siphon water out. To install them, melt the hole FIRST, then glue on the seaplane grommet. PLACE THE OPENING AFT! If you use dollar patches, be sure to cut holes for the vents.

Our STC allows for **melted holes** alone with no drain grommet. The only stipulation is that the melted drain hole needs to go through TWO LAYERS of fabric, that is, fabric with a tape over it. Handily, most of the areas you want to place a drain hole have tapes over them. Use a metal drain grommet as a melting guide to insure a smooth, even hole.

---

## Heat Smoothing

---

Pinked tape edges will often curl up when the **Gray Sealer** dries. To lay them down, use a **225° iron** and physically heat-form them flat. Pressure and heat will push the curled edges back down. Take your time on all the tapes; the hours you spend with the **225° iron** will save lots of sanding later.

### Imperfections You Should Fix

■ **Wrinkles.** Press with the tip of the iron really hard. Even those little crease wrinkles can be smoothed out.

■ **"Bubbles"** or areas in tapes and fabric that don't appear to be well stuck down. 225° works well at heat forming the bubbles flat.

Test it with your finger after you iron it flat. It should be firmly stuck down. Remember, don't worry about the natural fairings around rib laces. They only look like bubbles. Don't waste your time ironing them; you will never see them when the **Silver Urethane Fabric Primer** is applied.

■ **Lumps.** **Star-Tak** sometimes balls up into lumps when it dries off the brush as you apply it. Use heat and pressure to re-soften and smooth out the lumps left from the cementing stages.

■ **Curled Up Pinks On Tapes.** Pinked "ears" will often curl up when the **Gray Sealer** dries. Iron them flat with the **225° iron**. They will

## 5 - Let's Do a Wing!

heat-form and lay flat and smooth. Iron them now and you won't have to sand them later. Go over EVERY tape for a nice job. Let your fingers tell you when they are nice and smooth. **REMEMBER, NO MORE THAN 225° ON TAPES OR THEY WILL LOOK LIKE COKE BOTTLES.**

### Some Other Tricks

If you were sloppy with the **Gray Sealer** and have a lot of dried drips or runs, use some **Gray Sealer Reducer** on a rag to wipe them off now. You can do the same to level really big ridges of **Gray Sealer** next to the tapes. Don't use MEK; it's a bit too powerful and could take off all the underlying **Gray Sealer**. Be careful how much reducer you use and how hard you wipe. You could wind up plowing rag marks into the surface if you get too aggressive.

Do all the heat smoothing you possibly can now. Once we start spraying, it'll be too late. *Don't rush!* This is your opportunity to do it right.

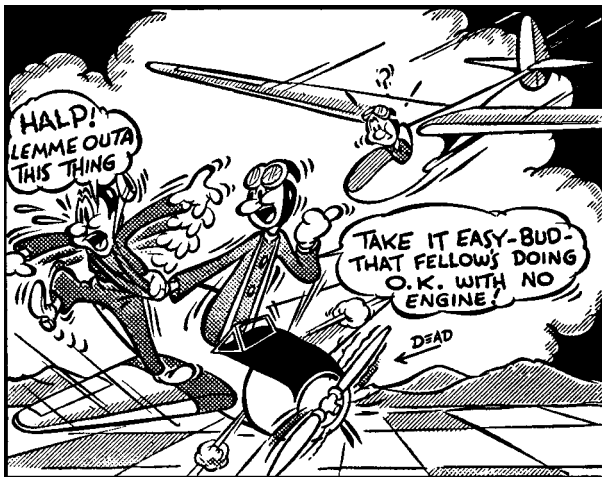

# NOTES

---

---

---

---

---

---

---

---

---

---

---

---



# 6 – Control Surfaces & Fuselage

## Ailerons

Ailerons are really just little wings, so nothing is different except that their narrow width gives you the option of using one piece of fabric instead of two.

Start by cementing the fabric to the trailing edge; then wrap it across the bottom, all the way around the leading edge, and back to the trailing edge. Cement it with a 1" overlap at the trailing edge, as you did on the wing itself.

You don't need to cement the fabric to the leading edge; there's no seam. The fabric will be plenty stable when you heat-shrink it and apply a coat of **Gray Sealer**. You'll find that the **Gray Sealer** will soak through the fabric on the leading edge and produce a cementing effect similar to **Star-Tak**.

## Tailfeathers

Elevators, rudders, and stabilizers are covered the same basic way you covered the wing, except you'll use **1" fabric-to-fabric overlaps** everywhere.

Most tailfeathers are made of tubing. Most of these tubes are  $\frac{3}{4}$ " or thicker. All overlaps will be done over this tubing. Depending on the width and shape of your tailfeathers, you can cover them with one or two pieces of fabric. We'll discuss using one piece of fabric for each tailfeather part. Using two pieces is done just the way you did the wings.

### Let's Take It Step by Step

Each tailfeather component has a straight edge with hinges sticking out from it.

**We'll use an elevator as an example.**

- Start by laying out flat on a large work table enough fabric to cover the elevator. Rest the elevator on its straight hinge edge in the middle of this fabric, with its trailing edge



sticking straight up in the air. The idea is to make a "clamshell" of fabric that will close over both sides of the elevator, pivoting on the leading edge tube. Using a soft lead pencil, carefully mark the hinge areas onto the fabric.

- Remove the elevator and make small cuts in the fabric at the marked locations to allow the hinges to stick out through the cuts. This allows the fabric to lie flat along the leading edge tube. Cement the fabric to the leading edge tube.

- **Heat-form the bottom fabric around the tube** before you cement it, providing at least a 1" overlap area, exactly as you did with the

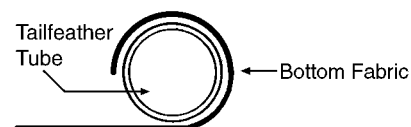

wingtip bow. Doing the bottom first will leave the trimmed edge of the top fabric down low where it won't show as much later.

## 6 - Control Surfaces & Fuselage



**Remember to leave about an inch of slack in the fabric.**

- **Brush Star-Tak onto the tube** where fabric will attach, then lay the fabric into the wet cement. Use a squeegee to **force the cement up through the fabric** until it wets out the surface. Make sure it penetrates the fabric. If you can, form and cement the fabric even further into the inside of the tube, as the illustration shows. This way, even more of the seam will be hidden.
- **Trim this seam neatly** with straight lines and no ravel. Clean up any excess **Star-Tak** spills or oozes with MEK.
- Once you have one side heat formed, cemented, and trimmed, smooth up the cemented area with a **250° iron**.
- Heat-form the top part of the fabric around the tube and cement it as shown below.

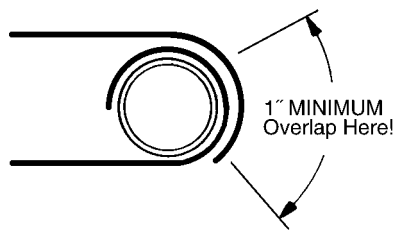

Leave at least a 1" overlap over the first piece.

- **Star-Tak** the cutline and, when dry, trim this seam neatly with sharp scissors. Don't use the razor blade here; there's too much chance of slipping and cutting the layer of fabric beneath. Make your trim cuts nice and straight with no raveled edges
- **Cement** the top fabric into place. Clean up any excess **Star-Tak** spills or oozes with MEK.

- **Cover the overlap with 3" tape. Use bias on curved areas.**

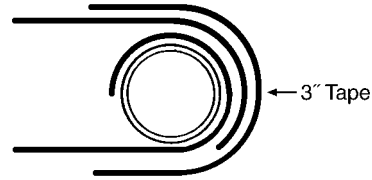

- **Again, pre-coating is the secret to adhesion.** Before you lay on any tapes, **brush two coats of Gray Sealer** over the area where the tape will be applied. Use a 2" brush. Make sure you don't leave a ridge of **Gray Sealer** at the edges. **Let this dry for 15 minutes.**
- When your 3" tape is ready to install, **brush a very wet stripe of Gray Sealer** over the pre-coated area. Don't skimp on the **Gray Sealer**. Work quickly. You may find it best to work in sections, applying only as much **Gray Sealer** as you can get the fabric into before it dries.
- **Lay the tape into the wet Gray Sealer.** Wipe the brush dry and use it as a tool to press the tape into the stripe of **Gray Sealer**. The dry brush can also be used to work out any big bubbles. Work fast and get the brush out of there before the **Gray Sealer** starts to dry.

---

## Fuselage

---

You absolutely need some safe, reliable means of turning the fuselage while you're covering it. Sawhorses aren't recommended for this, especially if you're going to use an envelope. More about this later.

Build the fuselage turning jig we showed you on page 5. It's just 2-by-4s, and it bolts right to the firewall. It can be turned to give you access to all sides of the fuselage. Use this jig with a padded sawhorse to support the tail.

## 6 – Control Surfaces & Fuselage



This simple fuselage turning jig makes covering your fuselage much easier.

There are two main methods of covering your fuselage – the blanket and the envelope. We'll discuss both.

### Option One: Blanket Method

The term “blanket” simply means a rolled-out length of fabric. It can be all one piece or two or more pieces sewn together.

Once again, you use the same basic procedures you used on your wings and controls to cover the fuselage. But unlike the wings and control surfaces, there are wide variations in fuselage designs, and that calls for careful planning if you're going to use the blanket method.

Think of the fuselage as a series of flat planes. After all, to this point, that's pretty much what you've been covering on the rest of the airplane.

The basic idea is to cover those flat planes by rolling out fabric in a series of blankets joined by 1" overlap cemented seams. Since a fuselage is usually made of tubing, most of your seams will be done exactly as was described in the tailfeathers section.

There are some constants to keep in mind when you make your plan:

1. The fabric is 72" wide. That is the maximum “reach” of the fabric you have to play with.

2. The fabric can only be joined with a cemented seam over structure.



---

**Fuselage “structure” is defined as longerons or cross tubes only. Formers and stringers don't count.**

---

Look at this uncovered J-3 fuselage.

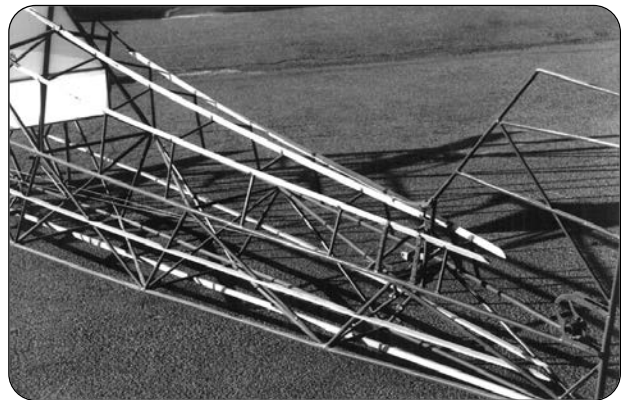

Notice the three wooden stringers on the top of the fuselage aft of the cabin. You can't create cemented seams over those stringers.

So you'd get out your tape measure and see where 72" fabric would reach between real structures, in this case the longerons. It turns out that there are four longerons stretching down the longest part of the fuselage in a box structure. Cutting to the chase, you would plan to cover the fuselage in three main sections: the top and the two sides – from longeron to longeron.

A separate belly piece should be attached first, wrapping around the two lower longerons.

Luckily, some airplanes have a real structure tube running right down the spine of the fuselage from the cabin to the vertical fin. That makes it easy. Here you can start with a 1" overlap over the spine tube, and then use two 72" pieces of fabric, one for each fuselage side. These two

## 6 – Control Surfaces & Fuselage

pieces drape from the center spine tube down each side and wrap around the lower longerons.

So much for planning. Let's talk about some unique things about cementing fabric to a fuselage.

Imagine that you're installing a piece of fabric straight down a slab-sided fuselage. You roll out the fabric, clamp it in place, and begin gluing.

But where do you start? **You start at the front, and work aft.** You begin cementing at a cross tube up by the firewall, or perhaps where the boot cowl will end. The way you cement fabric to this tube is different and critical. Here, it is impossible to have a fabric overlap. There will be nothing to overlap it with. You are at the start point, so this cement bond has to be extra strong.

To make it so, scuff-sand the primer or paint, then **pre-coat the tube with one coat of Star-Tak** and let it dry. Then **heat-form** the fabric carefully around the tube to get as much fabric as possible wrapped around that tube. Trim and cement it.



---

**Use this procedure for all your front tube starting places. In fact, you should pre-coat all longerons and tubing that are going to have a wrap-around bond.**

---

Sometimes, you must start front-end cementing on some fairly lightweight fuselage structures, not on nice thick tubes. For example, you might have to begin with the channel that holds the windshield or in a skylight well. **Make absolutely sure you get a good strong bond on these top cabin structures.** After all, the slip-

stream will be constantly trying to peel away these areas. And if the fabric peels here in flight, it can give you serious control problems by blanking out the elevators. **No fun at all!**

Many airplanes have mechanical attachments for the fabric in these areas. If so, replace them exactly as they were originally manufactured.

### Sometimes You Have to Sew

There are times when a cemented seam won't work. Our J-3 is a good example. After you cover the fuselage with overlapping seams over the longerons, you still have that big fin sticking up at the tail. It's easy to cover the fin with two separate pieces of fabric with cemented seams. But what about where the fin fabric joins the fuselage fabric? There's no structure under that seam, so you can't cement it. It has to be sewn and usually requires a hand-sewn seam.

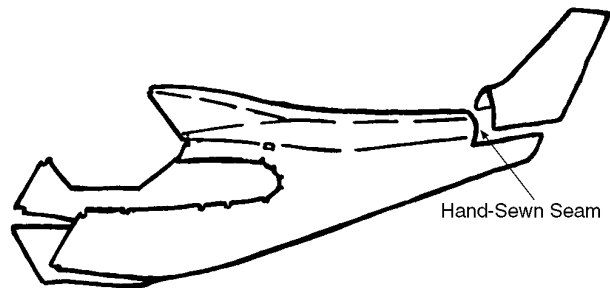

Sewing it is no big deal. Use a curved needle and doubled **Ceconite Hand Sewing Thread**. Pin the fabric together first with T-head pins, then sew as shown below. Remove the pins as you close the seam by sewing.

- First, tie the thread ends together in a square knot.

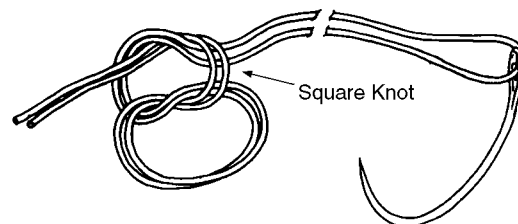

## 6 - Control Surfaces & Fuselage

- Then make one stitch from bottom, to top, and back to bottom. Pass the needle through the tied loop.

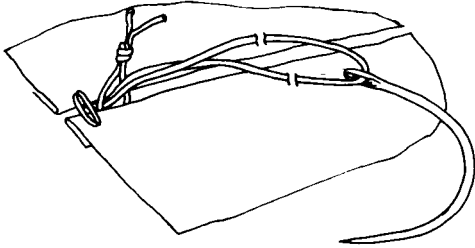

- Push the needle down through the lower piece of fabric, up through the space between the two pieces, and then down through the upper piece. This is called the “baseball stitch” for obvious reasons.

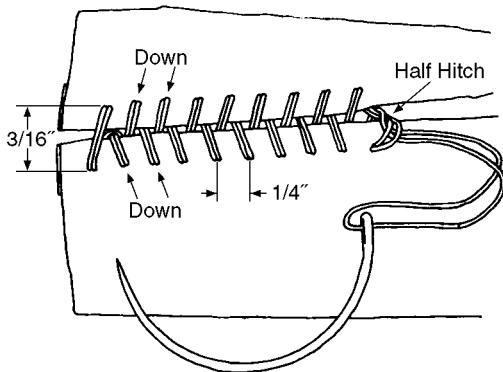

- Every ten stitches or less, work out the slack and secure the seam with a half-hitch. The end of the seam is tied off with two half-hitches in opposite directions, forming a square knot, topped with a single half-hitch.

Sewn seams are reinforced with a minimum 2" tape, centered over the seam.

### Option Two: Buy a Fuselage Envelope, or Make Your Own

An envelope is just a big “slip cover” or “sock” that has one end open so you can slip it over the fuselage.

Many people make their own envelopes or partial envelopes for all aircraft components. If you have a sewing machine that can handle **Ceconite machine sewing thread**, you can sew your own envelope. See Appendix A on sewing and envelopes.

Most people, however, buy a commercially made envelope. These envelopes are available from a few **Ceconite** distributors. Fuselage envelopes are made from time proven patterns and usually fit pretty well. Most envelopes have that “extra inch” of fabric built in to allow for shrinking.

If an envelope doesn't fit, it's usually a problem with the fuselage, not the envelope. Over the years, a fuselage may be repaired many times after damage. If it's not welded or repaired in a jig, its dimensions and alignment can change significantly.



You start by turning the envelope **inside out** so the sewn seam is hidden. Then you slip it on and clamp it in place. The front is wrapped and cemented to front structure using the pre-coating method described in the blanket method.

The envelope may have a separate belly piece. If so, the belly piece is installed first with 1" overlaps. This way, the edges of the envelope fabric are hidden underneath the fuselage.

## 6 - Control Surfaces & Fuselage

Now that you have read about fuselage covering with both envelopes and blankets, the decision is yours. We find, however, that well-made commercial envelopes for fuselages are almost always time savers compared to piecing the fuselage together with the blanket method. They cost more than using blankets, but the result is clean and professional.

---

### Final Steps!

---

Now that your control surfaces and your fuselage are completely covered with fabric, there are some more steps to complete before it's time to crank up the spray gun.

- Heat tighten all the fabric, just as you did on the wing.
- Cut the fabric to accommodate any protrusions.
- Brush on the first coat of **Gray Sealer**.
- Apply any reinforcing tapes needed.
- Do any rib lacing necessary.
- Install inspection hole reinforcements and drain grommets.

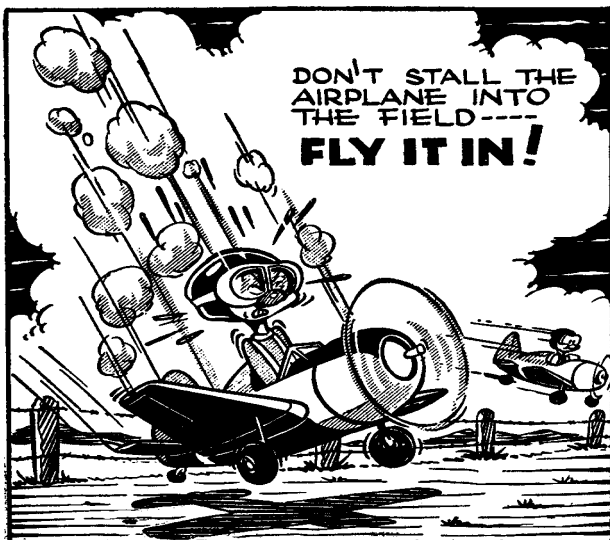

# 7 - Spraying Silver Urethane Fabric Primer

**Silver Urethane Fabric Primer** is made from the same high- quality polyurethane resin as **Ranthane** topcoat paint. Thus, the primer and the **Ranthane** topcoat will form a consistent coating that bonds and works together. **Silver Urethane Fabric Primer** has two purposes: first, to provide a build coat to fill the fabric and act as a base for **Ranthane** colored topcoat, and second, to provide UV protection to the fabric.



**A metallic flake product is added to Silver Primer to provide UV protection. Silver Primer does it the old fashioned way without relying on less effective chemical UV blockers.**

## What Spray Rig Do I Use?

You can use either a classic suction **Binks** or **DeVilbiss** gun that is powered directly by a compressor. Make sure you have water traps, filters, and a compressor and tank sufficient to keep the air supply constant when spraying. You should have about 50 psi at the gun when spraying. Use any nozzle, needle, and aircap combination recommended for spraying lacquers, enamels, or automotive polyurethanes.

HVLPs work great. You can use either a conversion high-volume low-pressure (HVLP) that works off a compressor or one of the turbine-powered HVLPs. Again, our favorite rig is the **Citation** by **Axis Products**: great gun, and a forced air breathing system to boot.

## Here's an Overview of the Basic Spraying Steps

1. First, make doubly sure you have heat smoothed the tapes.
2. Spray the first cross coat of **Silver Urethane Fabric Primer**; allow it to dry to the touch.
3. After drying for at least one hour, spray a second cross coat.

Wait overnight for these coats to dry fully, then wet-sand any imperfections, rough pinked edges of tapes, or runs with 320-grit paper.

**Now let's discuss these steps in detail:**

## What's a Cross Coat?

A cross coat is simply two coats applied 90 degrees to each other. For example, you spray a wing down its entire span with one coat going east and west, then spray another coat down the chord going north and south. That's one cross coat. The idea behind the 90-degree pattern is to avoid "tiger striping" that leaves incomplete areas of UV protection.

## The Biggie: Heat Smoothing With an Iron BEFORE You Spray Silver Urethane Fabric Primer

This is your one last shot at a good covering job. The pinked edges of tapes often pop up from the surface or appear rough after application. You can easily iron these rough edges down now: the iron will heat-form the pinked edges and soften the **Gray Sealer** used to apply them. Make sure the pinked edge tapes have been heat-smoothed at 225°. Keep ironing until you can feel no rough edges when you rub your fingers

## 7 – Spraying Silver Primer

over tape edges. Do a thorough job now; you'll be unable to smooth tapes with heat after you spray **Silver Urethane Fabric Primer**.



---

**Remember! You must wear a fresh air source respirator when spraying all polyurethanes, Silver Primer included. The spray mist of all polyurethanes is toxic! A charcoal mask will not hack it!**

---

### Spraying

#### Practice With Your Spray Rig

Catalyze and thin some **Silver Urethane Fabric Primer** and practice on test panels or scrap parts. DON'T LEARN ON YOUR AIRPLANE. *Practice first.* Try vertical panels; see what it takes to make it run, then don't do that again. Be critical on how smooth your practice coats are. When you think you're ready, spray your airplane.

#### Mixing Silver Primer

First, stir the **Silver Urethane Fabric Primer** with a paint paddle to insure that all the solids in the bottom of the can are back in suspension. Then put the can on a double-action paint shaker and shake it for at least five minutes.

Mix four parts **Silver Urethane Fabric Primer** to one part **Silver Urethane Fabric Primer Catalyst**. Mix only what you plan to spray; no sense mixing it all. If you don't use it, it'll harden and be wasted.

Let the catalyzed **Silver Urethane Fabric Primer** sit for 20 minutes induction time. Then thin the catalyzed **Silver Urethane Fabric Primer** 33% with **G-4200 Ranthane Thinner**.

**As a rule of thumb, this is three parts catalyzed Silver Primer to one part G-4200 Thinner (3:1).**

Before you spray, pour the thinned catalyzed **Silver Urethane Fabric Primer** through a paint strainer. Our distributors can provide 60 x 48 mesh strainers, but any strainer used for automotive paint and primers should work.



---

**Don't make your first pass on your airplane. We will say this again; try a test panel, hopefully one set up vertically. Make sure you can spray a moderate wet coat that has no orange peel and does not run. If it looks good, go on to your airplane.**

---

#### Cross Coat One

Spray a moderate coat, enough to wet the surface with a smooth liquid coat. Don't flood it on; more is not better.

When you have finished in one direction, spray the second pass of the cross coat. If the first pass dries before you spray the second, no problem.

Wait at least two hours. Why rush?

#### Cross Coat Two

Spray the second cross coat just like the first.

Now wait overnight for both cross coats to dry fully. Overnight is the bare minimum; if you wish to wait longer, a week, a month, etc, no problem. If you don't have a turning jig and you are laying the part on sawhorses, you should wait at least overnight before turning the part over. Again, longer is better. No sense messing up your spraying with sawhorse marks. If you are unsure, wait! Plan things out; spray multiple parts on one side, instead of spraying one part at a time and having to hold up progress waiting to turn the part over.



---

### Sanding

---

When you turn over a part to paint the second side, there are usually areas that are coated with some **Silver Urethane Fabric Primer** from painting the first side. A good example is the leading edge of a wing. After you paint the first side and turn it over, you will have at least half the leading edge already coated. Before you apply more primer over these areas, scuff sand with a gray Scotch-Brite pad to make the new **Silver Urethane Fabric Primer** stick to the coats applied on the first side. If you don't, you may not have good adhesion on the overlapping coats.

Now that all the **Silver Urethane Fabric Primer** has been applied, it is time to sand the entire part, top and bottom. Wet sand using 320 or 400 grit. Make sure you wet sand pinked tape edges, spray imperfections, and any areas that are rough. Keep the surface clean: after sanding, wipe well with clean rags to remove residue sanding mud. Take care not to sand off too much; you need a good silver layer for UV protection. If you take off too much, you may need to spray additional **Silver Urethane Fabric Primer**. As a rule of thumb, you need enough silver to block light passing through the fabric.

---

**WARNING! Don't sand over rivet heads, rib laces, or any hard edges that could cut the fabric. Only a few passes of sandpaper can damage fabric over protrusions. Also, make sure you remove all residue sanding mud. Dried residue can impede the bond of the next coat, so make sure it is all removed. If necessary, use a Scotch-Brite pad around rib laces or protrusions to insure you don't harm the fabric.**

---

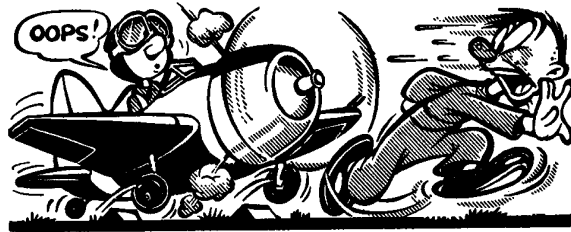

# NOTES

---

---

---

---

---

---

---

---

---

---

---

---

---

# 8 – Spraying Ranthane Topcoat

**Ranthane** is our glossy, wet-look polyurethane that represents the latest technology in high-solids flexible paint. Unlike automotive polyurethanes, it is specially formulated to flex and move on aircraft fabric and requires no plasticizer additives. Although flexible enough for fabric, it works great on epoxy-primed metal or composite surfaces.

**Ranthane** is made from the same polyurethane resin as **Silver Urethane Fabric Primer**; both work together to give a flexible, glossy coating that protects fabric from UV and gives long service life.



**Ranthane is the only FAA-approved topcoat paint in the Star Gloss system. If you substitute any other topcoat paint, it voids the STC.**

*How long should I wait before I spray Ranthane over Silver Urethane Fabric Primer on fabric or epoxy primer on metal or composites?*

Although in optimum warm and dry conditions you can spray the next day, the safe answer is one week. There is good reason for this.

It takes a full week for catalyzed primers to cure. Yes, they may dry to the touch in minutes, but chemical curing or crosslinking takes a full week. Crosslinking insures that polyurethane or epoxy primers are fully chemical resistant and not damaged by the solvents in the topcoat paints that are sprayed over them.

Let's be clear – if you are in a hurry, you can spray **Ranthane** one day, two days, or three days after applying primer, but you stand a chance of wrinkling paint, causing unnecessary pinholes or weakening the final combination of primer and **Ranthane**. In warm, dry Southern

California weather, we have sprayed **Ranthane** over **Silver Urethane Fabric Primer** one day after applying the primer with no problems. Remember however, that you increase the chance of problems in lower temperatures or higher humidities when you rush the job. Best bet is to wait for a week if you can.

So the bottom line is: spray **Silver Urethane Fabric Primer**, then wait as long as you can up to a week (longer is OK) to permit the primers to fully crosslink. If you insist on spraying **Ranthane** into **Silver Urethane Fabric Primer** earlier, you may or may not have problems. Why take the chance? Paint and chemistry does not care about personal scheduling problems; it doesn't care that you are in a hurry; it reacts in predictable scientific ways and waiting keeps things trouble free.

## Step One: Prep the Silver Urethane Fabric Primer or Epoxy-primed Metal Surface

1. Scuff-sand the fabric surface with an ultra-fine (dark gray) Scotch-Brite pad. Scuff just enough to impart tooth adhesion. No need to use much pressure; when the surface dulls down just a bit, you are doing the job correctly.
2. Lightly wipe the scuffed surface with a rag just barely damp with **C-2210 Paint Surface Cleaner**. This removes finger oils and light contaminants. Do not soak the rag, damp is fine. If you soak the surface with **C-2210** and then paint, the **Ranthane** could pull away from the solvent on the surface. Wait two hours for the solvents in the **C-2210** to evaporate.
3. Wipe with a tack rag. **DON'T PRESS HARD!** The idea is to remove dust by gliding the

## 8 – Spraying Ranthane Topcoat

tack rag over the surface just before spraying. If you press hard, you can smear the tacky stuff over your cleaned surface.

---

### Step Two: Mix, Catalyze, Thin, and Filter the Paint

---

1. Stir the paint with a stirring stick, and when all the solids are mixed from the bottom, put the can on a double-action paint shaker for at least five minutes.
2. Add two parts paint to one part **AU-2X1 Catalyst**. Use a graduated paint mixing cup, a ladle, or small cups. Mix only what you plan to spray in the next session, don't mix it all at once.
3. Let the catalyzed **Ranthane** sit for 20 minutes induction time.
4. Thin the catalyzed **Ranthane** three parts to one part **G-4200 Thinner**. This is a starting point; you may need more.
5. Filter the mixture through a paint strainer. You can obtain 60 x 48-mesh strainers from any Randolph/Poly-Fiber distributor.
6. You should have several hours pot life to use the paint, but that can decrease in hot or humid weather. If the paint gets thick, discard it.

---

### Step Three: Test Spray

---



**Remember, you must wear a fresh air source respirator when spraying all polyurethanes, Ranthane included. The spray mist of all polyurethanes is toxic! A charcoal mask will not hack it.**

1. Get an old part, scrap panel, flat piece of metal, or an empty oblong gallon thinner can.

2. Lay the practice piece flat and spray a tack coat. A tack coat is just a fine mist of paint with a hint of color. Let it dry to the touch.
3. Now spray a moderate coat (shiny but not heavy). Let it dry to the touch and examine for orange peel. If you have orange peel, add additional thinner until it disappears. The deal is to learn what the correct thinning ratio is before you point the gun at your airplane.

**You can add up to one additional part of thinner to the current mix to fix orange peel.**

#### **Recap:**

Start with: 3 parts catalyzed paint + 1 part thinner.

You can go up to: 3 parts catalyzed paint + 2 parts thinner.

Hopefully this fixes orange peel.

4. Now repeat this process with the test piece standing on at least a 45-degree angle. See what it takes to make it run on the vertical. See what it takes to keep it from running. In other words, test for sufficient thinning to stop orange peel without running the paint.



---

**Never spray your airplane without testing on something else!**

---

---

### Step Four: Paint Your Airplane. Spray a Tack Coat, a Moderate Coat, and a Wet Coat. Cross Coats Are Not Required.

---

1. Spray a tack coat. A tack coat is just a fine mist of paint with a hint of color. Let this dry to the touch.

## 8 – Spraying Ranthane Topcoat

2. Now spray a moderate coat. A moderate coat is shiny but not heavy. Hopefully, when practicing, you learned how much thinner to add to prevent orange peel. Just in case, however, let's review proper thinning again:

Start with: 3 parts catalyzed paint + 1 part thinner.

If you need more thinning, you can go up to:

3 parts catalyzed paint + 2 parts thinner.

3. Let this coat dry at least an hour, then spray a third wet coat (heavier than the second), but take care not to run. This third coat should be sufficient. **But, if you wish, you can add a fourth coat if you think it needs it.**

*“How long between coats?”*

The best bet is to spray all coats on the same day with at least an hour between coats.

But what if you get interrupted and can't spray all coats the same day? As we said above, all polyurethane paints take a full seven days to cure (not just dry) to full solvent resistance. If you spray a heavy coat of **Ranthane** over a coat that has been applied before full cure (for example two days old), it could wrinkle.

To avoid any possible problem, spray two coats in one day and you will have no possibility of wrinkling. If for some reason you spray one coat and then get interrupted, wait a full week for the first coat to cure, then scuff-sand, then spray the second coat.

*“I'm putting my parts on sawhorses. When can I turn them over?”*

First of all, a turning jig is a great aid. If you can figure out a simple fixture to turn wings without laying them on sawhorses, it'll be a great help. If you're using sawhorses, you need to allow the

paint to dry sufficiently before you turn the wing over to avoid damaging your nice fresh paint. Depending on temperature, 24 hours is usually sufficient. As in everything with painting, don't rush it. If you can wait longer, great. Nothing worse than sawhorse marks in a beautiful new paint job.

Remember that after turning the part over, any paint that was applied on the first side must be scuff sanded before you overlay paint on the second side. Use a grey Scotch-Brite pad. If you don't scuff the first coats, the new paint will not adhere well.

---

### Step 5: Trim Painting

---

For best results, wait a full week before you paint the trim. Waiting a full week allows the base color coat to fully cure for full chemical resistance. If you absolutely must paint trim before a week transpires, understand that heavy coats of trim paint could wrinkle the base coats, so if you must, keep them light. This is not unique to **Ranthane**; all polyurethanes react this way.

After waiting a week, use high quality polypropylene masking tape; avoid cheap paper tapes that don't seal well and have leaks. After taping, scuff-sand the area between tapes where the trim paint will be sprayed with ultrafine Scotch-Brite or 400-grit sandpaper. Take care not to fuzz the edges of the trim tape.

If you absolutely must spray trim paint before a week is up, do a tape test. Put a piece of tape on some part of the base color that will not show. Leave it on for the number of hours that you think the tape will be stuck on when you are actually trim painting. Pull the test piece of tape and inspect for tape tracks or damage to the **Ranthane**. If there is no problem, proceed with the real thing.

---

### Flattening

---

If you are doing a military aircraft or perhaps a glare shield and you want to bring the **Ranthane** to a semi-gloss or flat finish, use Randolph **Flattener**. See the instructions in the Product Profiles, Appendix G.

---

### Fixing Problems

---

1. **Runs:** Quit painting and let the surface dry at least four days. Sand out the runs with 400 grit. A week after you sprayed the first coat, scuff-sand the surface and respray.
2. **Grit in the paint:** First check your gun for cleanliness. Most trash in paint comes from dried residue in the spray gun busting loose inside and entering the paint. Field strip the gun; clean everything with pipe cleaners and brushes. Make sure all internal parts are hospital clean. Then check the environment. Make sure the filters in your spray booth are clean and that you are not blowing dust off the floor or sides of the booth with your spray gun.
3. **Orange Peel:** Turn down the pressure on your gun and add more thinner. See the thinning directions in **Step 3** and **Step 4** above.
4. **Fish Eye:** Fish eye is caused by the paint film crawling away from contaminates on the surface being sprayed. Let the surface thoroughly dry, then wash the area well with **G-4200 Thinner**. Follow with a clean rag, and spray again.

# Appendix A: Envelopes and Sewing

## Envelopes

Think of an envelope as a huge sock, or a slip-cover to simplify the covering of a fuselage, a wing, and tailfeathers. Envelopes are sewn on three sides, with an open seam to allow you to pull it on.



After envelopes are slipped on, they're cemented closed at the open seam. Heat shrinking and **Gray Sealer** then hold the envelope firmly in place. It is not necessary to cement around the entire perimeter of the frame as done with the blanket method.

Envelopes are sold by a few aircraft supply houses. Quality envelopes come from proven patterns, most fifty or more years old. If they don't fit, it's usually the fault of a bent or modified airframe rather than the envelope.

### To Install an Envelope:

- Turn the envelope inside-out so the sewn fringe is on the inside.
  - Pull the envelope over the part. There should be about an extra inch of fabric at the perimeter.
  - Straighten the fringe on the inside of the envelope. If you let the fringe bunch up or snake back and forth, you will see it forever.
- Clamp the envelope in place with spring clamps or clothespins.
  - Cement one side of the open seam to the aircraft structure with **Star-Tak**. Cement the other to make a closure with at least a one-inch overlap.
  - Take the clamps off one side at a time, and heat shrink at 250°, **STARTING OVER THE SEAM**. If you shrink from the seam out, the seam stays straight. On the other hand, if you go first to the center of the part to shrink, it will pull the seam toward the iron and leave snaking, off-centered seams.
  - Shrink the whole envelope from the seams out at 250°. Then repeat at 350°.
  - Brush on **Gray Sealer**, and follow the normal **Star Gloss** procedure. You must put a finishing tape over every sewn seam in the envelope.

### Envelope Pros and Cons

#### PROS:

- ◆ Huge time savers on fuselages. Fuselage envelopes usually are pulled on from the tail. The separate belly piece is cemented into place first, wrapping around the lower longerons. Then the sides are wrapped around the longerons with 1" overlaps, and the edges end up hidden on the fuselage bottom.

- ◆ Envelopes take the fitting and planning time out of fabric installations.

#### CONS:

- ◆ Lots of fiddling with inside fringes.

## Appendix A: Envelopes and Sewing

- ◆ Wing envelopes usually have chordwise sewn seams. These seams do not fall over ribs. This gives extra seams to worry about shrinking straight and taping. Some manufacturers offer span-wise seams.

---

### Sewing

---

There is little need for sewing when covering with **Star Gloss**. The only time a sewn seam is required is when fabric must be joined over an open area with no adequate sub-structure underneath. This rarely happens.

The illustration below shows the one instance in Cub and Aeronca type fuselage where sewing is required. Here there is no substructure where the fuselage fabric joins the fin fabric. Thus, a sewn seam is required.

There are two kinds of sewn seams approved with our STC, hand sewn and machine sewn.

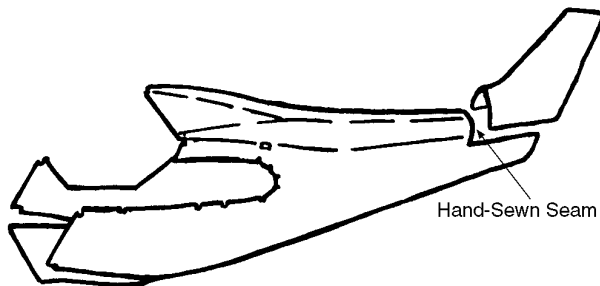

#### Hand-Sewn Seams

The instance above is a good candidate for a hand-sewn seam.

- Start by folding the edges of the fabric on both sides of the seam at least  $3/8$ " to the inside of the seam.

Use an iron to crease this  $3/8$ " fold. This folded part will give two layers of fabric at the edge for extra strength.

- Temporarily join the seam with T-head pins. As you sew, you pull out the pins just ahead of your stitching.

Use only 15 lb **Ceconite Hand Sewing Thread**, doubled. A 3" or 4" curved needle works great.

- Sew with a baseball stitch with a maximum of  $1/4$ " spacing. The sewing holes must be a minimum of  $3/16$ " from the edge of the seam.

See the illustrations below:

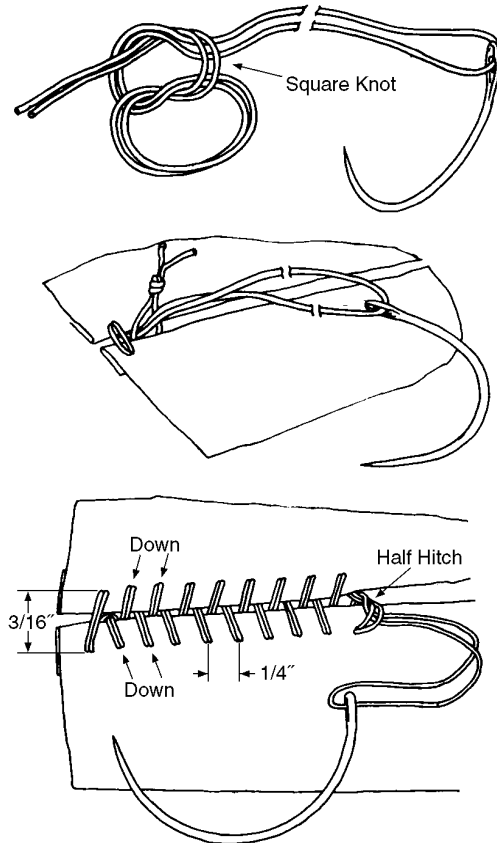

- When the sewing is over, heat shrink normally and put a 2" finishing tape over the seam.

#### Machine-Sewn Seams

Most of us will never need to machine sew anything. If you have a sturdy sewing machine and have the skill and interest to sew your own seams, read on.

Always use only **Ceconite 10 lb Machine Sewing Thread**. Do not use cotton thread or upholstery thread; they will rot in short order.



## Appendix A: Envelopes and Sewing

The following seams are approved for sewing aircraft fabric:

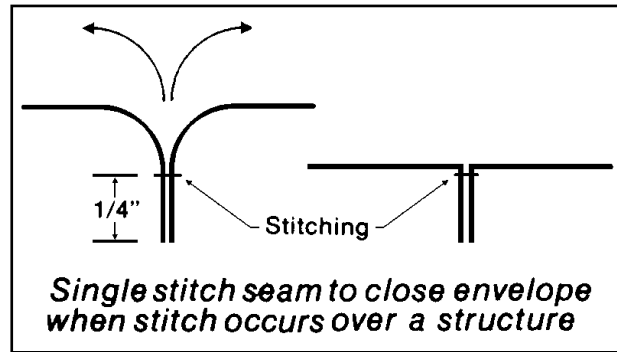
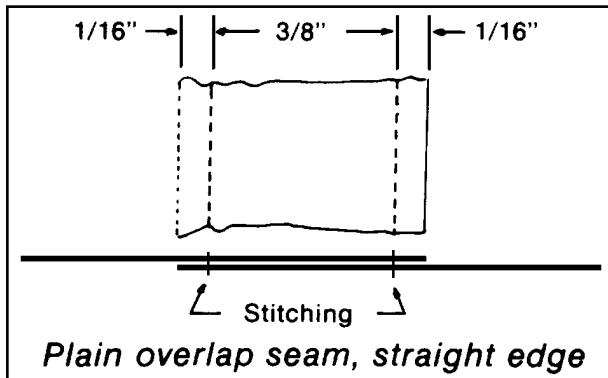
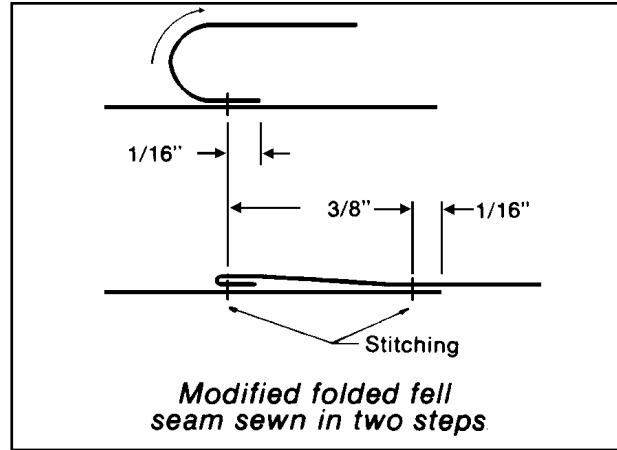
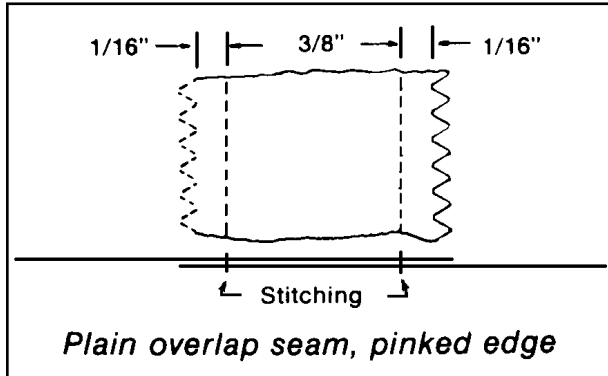

All sewn seams must be covered with at least a 2-inch finishing tape.

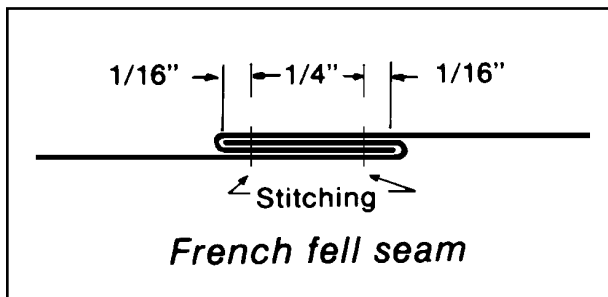

### Make Your Own Envelope!

There's one time you may be interested in sewing. If you wish, you can sew your own simple fuselage envelope. Here's how:

- Unroll a single piece of fabric long enough to stretch from the rear of the fin to the forward cabin area.
- Clamp this fabric to the fin and continue clamping down the fuselage to the front of the cabin. Clamp around a forward fuselage tube by the boot cowl where you would normally cement the fabric to the frame at the front of the fuselage.
- If this is going to work for you, this one piece of fabric should be wide enough to cover the

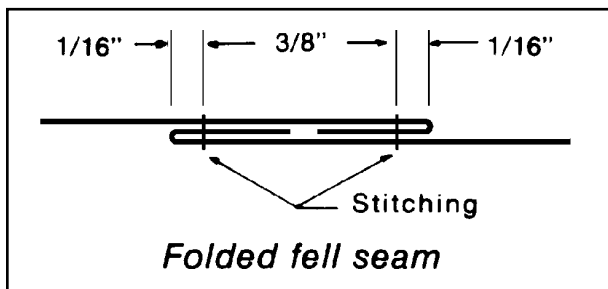

## Appendix A: Envelopes and Sewing

distance from the top of the fin to the lower fuselage longerons, as well as the whole cabin area from top to bottom. In other words, you should be able to cover the whole side including the fin with one 70-inch-wide piece of fabric.

- Unclamp the top part of the fabric and lay it over the centerline of the turtleback. Most airplanes have a flimsy wooden stringer here as the top “spine.” **Remember, you can’t make a cemented seam over a stringer;** it must be a longeron. That’s what all this sewing is about.
- Trace this spine with a **soft lead pencil**. This will be the pattern for a single seam we will sew to join our envelope at the top.
- Unclamp the fabric and lay it on the floor. Put a duplicate piece of fabric the same length directly over it. Pin the two pieces together with T-Head pins.
- Sew the two pieces together at the pencil line using one of the seams illustrated above. Or take it to a commercial seamstress. Make sure you bring the **Ceconite Machine Sewing Thread**.
- Cut out the excess fabric on the top side of the spine seam. Turn the envelope inside out and drape it over the fuselage. Hopefully, it lies smoothly over the fin and has a straight seam all the way up the turtleback over the spine. It should be long enough to drape over the fuselage sides below the lower longerons.
- Make a belly piece and cement it to the lower longerons with 1” overlaps.
- Cement the side pieces to the belly with 1” overlaps. Finally, cut out the window areas and cement as appropriate to the cabin areas.

There are other instances where you may choose to sew. As long as you use one of the approved seams and use **Ceconite Machine Sewing Thread**, you can make whatever your sewing skills allow.

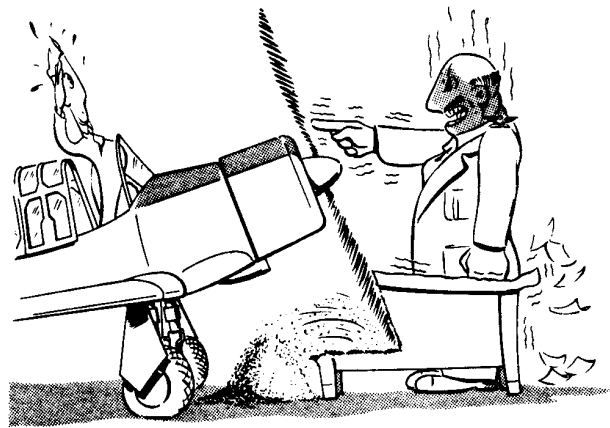

It’s always a good idea to make sure your brakes are in working order before taxiing.

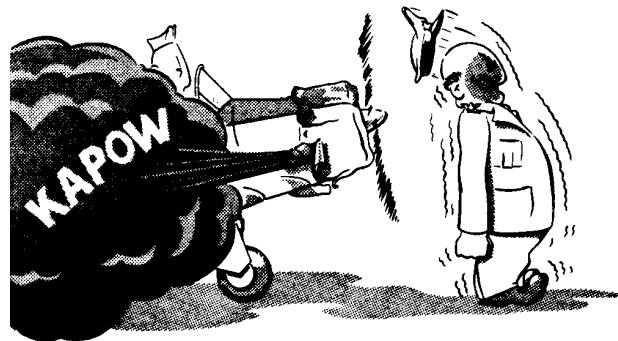

Avoid making abrupt mixture changes, especially on the ground.

# Appendix B: Concave-bottom Wings

Concave-bottom wings require a different sequence of steps.

**The basic plan** is to rib lace earlier than normal in order to hold the fabric into the concave lower shape while heat shrinking.

If you cover a concave wing following the steps in normal sequence, the heat shrinking at 300 or 350° will pull the fabric off the lower ribs. You'll wind up with a flat plane on the lower surface rather than the desired concave curve, and your bottom fabric won't be attached to anything.

---

## Follow These Steps

---

- Before you attach any fabric, brush the LOWER rib capstrips *only* with two coats of **Star-Tak** cement. Let the **Star-Tak** dry.
- Now attach the upper and lower wing fabric exactly as described in the main section of this manual.
- If you are planning to rib lace (and we STRONGLY encourage you to do so), *do not* cement the fabric to the top surface ribs.
- Mix a solution of **Star-Tak** thinned 1 to 1 with MEK. Brush this into the fabric over the *bottom* rib capstrips.

This solution will soak through the fabric and soften the **Star-Tak** previously applied to the bottom rib capstrips. This will cement the fabric to the concave bottom curve of the ribs.

- After the **Star-Tak** has thoroughly dried, heat-shrink the fabric on both the top and bottom of the wing at 250°.



---

**DO NOT GO ANY HIGHER THAN 250°! If you do, you will almost certainly pull the fabric away from the cement!**

---

- Do not apply **Gray Sealer** yet! Put on the reinforcing tape and rib lace the entire wing.
- When finished rib lacing, heatshrink at 350°, or 300° if recommended by your kit manufacturer.
- The rib lacing will hold the fabric to the concave lower wing shape.
- NOW apply **Gray Sealer**, tape, and get back in the normal sequence.



# NOTES

---

---

---

---

---

---

---

---

---

---

---

---

---

---

# Appendix C: Covering Plywood Surfaces

Fabric covering over sheet plywood has been a popular way of adding strength and hiding wood grain since the '20s. Bellancas and Mooneys are known for their fabric-over-wood construction.

Any **Ceconite** fabric can be used to cover plywood. Our **Uncertified Light** is the most popular choice for its smooth finish and workability.

## Prepare the Surface

- Fill low spots and imperfections in the wood with Poly-Fiber **SuperFil**. Sand smooth.

## Varnish

- Varnish over the wood and **SuperFil** with **EV-400 Epoxy Varnish**.

Combine one part **EV-410 Catalyst** to two parts **EV-400 Epoxy Varnish**. Let this soup "cook" for 30 minutes. Filter through a 60 X 48 paint filter. Thin two parts catalyzed varnish to one part **E-500 Epoxy Thinner**.

- Brush or spray two coats of varnish. Allow the first coat to dry to the touch before spraying the second. If you let more than four days go by between coats, lightly scuff-sand the first coat.

For best results, let the varnish dry for a full seven-day crosslinking cycle before you try to put any **Gray Sealer** or **Star-Tak** over it. If you try it earlier, the varnish may wrinkle or lift.

## Gray Sealer Alternative to Varnish

**Gray Sealer** can be used as a wood sealer, but it doesn't provide the long-term protection of epoxy varnish. If you skip varnish, you can brush **Gray Sealer**, thinned two parts **Gray Sealer** to one part **Gray Sealer Reducer**, directly into the bare wood. Two coats should do it.

## Pre-Coat With Gray Sealer

- Brush one coat of **Gray Sealer** reduced three parts **Gray Sealer** to one part **Reducer** over the varnished or **Gray Sealer** sealed surfaces.

Allow to dry. Spray on another coat, thinned three to one. This pre-coat will help fabric adhesion and prevent pinholes.

## Apply Fabric

- Cement the fabric exactly as described in the main section of this manual. There is no difference to cementing fabric over wood; all overlaps and heat forming techniques remain the same.

## Heat Shrink

- **Start with the iron at 225°, NO HOTTER!** The idea is to only take the wrinkles out of the fabric. If you go to higher temperatures, you could pull the fabric out of the natural wood depressions. This bridging could give unwanted air pockets under the fabric.

If 225° leaves some wrinkles, selectively go up to 250°. Be careful not to cause bridging.

## Gray Sealer

- Thin **Gray Sealer** three to one with **Reducer**. Brush it over the fabric. The thinned **Gray Sealer** will soak through and reactivate the precoated **Gray Sealer** below.

If any bridging is apparent, wait about 30 seconds for the **Gray Sealer** to get tacky, and brush again over the depression. The tacky **Gray Sealer** should stick the fabric down into the depression.

If the worst occurs and the fabric will not stay in a deep depression, slit the fabric carefully with a razor to cut the bridge. Patch later with a piece of fabric or tape and **Gray Sealer**. Careful filling and preparation should avoid this from ever happening.

## Tape and Spray Silver Urethane Fabric Primer

- Continue the process as written in the main part of this manual.

# NOTES

---

---

---

---

---

---

---

---

---

---

---

---

---

---

---

# Appendix D: Airworthiness Limitations

1. As a minimum, fabric and coatings must be inspected once a year as part of the aircraft's annual inspection.
2. If for any reason the fabric's integrity is questioned, the fabric must have a breaking strength of 56 pounds per inch or more to be airworthy.
3. This 56 pounds per inch minimum is required for fabric manufactured to the standards of FAA Technical Standard Order (TSO) C-15 d/AMS 3806c. Our **Ceconite 101** and **Ceconite 102** fabrics are manufactured to TSO C-15 d standards.
4. Inspection procedures:  
See Appendix E of this manual, Inspecting Fabric and Coatings, for complete inspection procedures.
5. The Airworthiness Limitations Section is FAA approved and specifies maintenance required under Secs. 43.16 and 91.403 of the Federal Aviation Regulations unless an alternative program has been FAA approved.

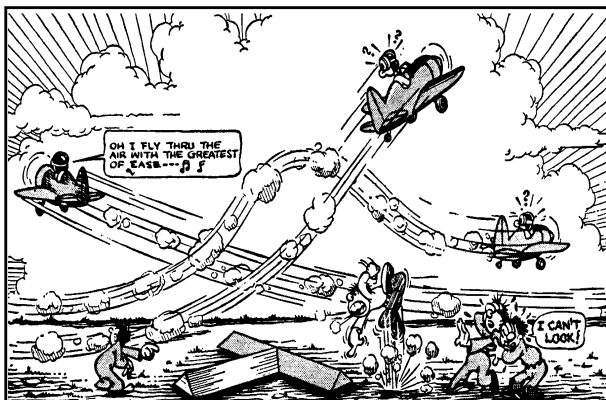

# NOTES

---

---

---

---

---

---

---

---

---

---

---

---

---

---

---



# Appendix E: Inspecting Fabric & Coatings

**Ceconite fabric and Star Gloss coatings and paint applied to it must be inspected each year at annual.**

The core concept is that the paint and coatings should remain in good shape to protect the underlying fabric, so the condition of the paint and coatings is important. The age of a cover job is irrelevant; good jobs easily last 25 years, some much more than that. If the job was done correctly with plenty of UV blocking silver, it will last indefinitely, well past the time when a smart owner will want to uncover the airplane to see the state of the airframe under the fabric.

Remember that UV radiation is the only thing that can degrade polyester fabric; it's not affected by gasoline, fungus, rot, or weather extremes. So if you want to protect the fabric, you have to have a "sheet of metal" between the fabric and the sun. That sheet of metal is, in fact, the metallic additive in **Silver Urethane Fabric Primer**. The bottom line is: if there is sufficient aluminum to block and reflect the passage of light, it also blocks the passage of damaging invisible UV radiation.

---

## Inspection Procedures

---

Here are the steps an experienced IA will take. If he is unfamiliar with inspecting fabric, show him these procedures:

1. Inspect the general condition of the paint and coatings. If the fabric is flexible and resilient when pushed hard with a knuckle, *Good!*
2. Find a way to view the fabric from the inside out. On fuselages, this can be done by removing sufficient interior components to see the

inside. On wings or some tailfeathers this can be done by removing an inspection cover so you can see the inside surface of the fabric. Have an assistant hold a 60-watt shop light one foot from the outside surface to simulate sunlight. As you view the fabric from the inside, there should be enough **Silver Urethane Fabric Primer** so that no light is visible from the shop light held a foot off the surface outside.

If the coatings and paint block the light, *Good!*

**BASED ON PASSING THESE TWO TESTS ALONE, THE IA COULD HAVE CONFIDENCE THAT THE FABRIC IS AIRWORTHY.**

---

## The Problem Scenarios

---

1. The paint and coatings are brittle, cracked, and ringwormed. They readily crack when pushed with a knuckle: *Bad!*

BUT, as long as there are no big chunks out of the paint, and there is no sun-exposed fabric, the airplane is still airworthy, but should be monitored for problems continually until the next annual inspection.

2. Big chunks out of the paint and coatings, advanced peeling, sun-exposed fabric: *Really Bad!*

The IA can use a Maule Fabric Tester on the bare fabric as an aid to see if there is UV damage.



## Appendix E: Inspecting Fabric & Coatings



**AC 43.13 - 1B states that a Maule Tester is not approved for determining airworthiness; it is only an aid. Also, Maule Testers only give an accurate reading on bare fabric. It does no good to "punch" painted fabric; you are measuring the combined strength of the paint and fabric. The FAA only cares about the fabric. To use the Maule, push until it reads 56 lb; no need to push further and punch a hole in the fabric unless the IA is seeking additional business repairing your unnecessary holes.**

3. If the Maule Tester indicated that the fabric is questionable: do the "Hang It On the Wall" test. This is a simplified version of an FAA acceptable field test for fabric testing that is published in the fabric covering section of AC 43.13 - 1B.

### The "Hang It on the Wall" Test

1. Cut a strip of fabric from a sun-exposed area of the aircraft (hopefully the top), four inches long by one and one-quarter inches wide. Clean all the coatings and paint off the fabric strip by soaking it in MEK.
2. Unravel a few threads from the side so it has a small "fringe." The unraveled fabric should be one-inch wide.
3. Figure out a sturdy way to hang the strip on a wall; put an equally sturdy hook on the other end. An easy way to do this is to sandwich the fabric ends between two pieces of metal or wood held together with hardware. Strengthen the sandwich by wrapping and cementing one end around one of the pieces of wood or metal to prevent slippage.

4. Put a bucket on the hook and fill it with 56 pounds of sand, lead, gold, or anything heavy you can accurately weigh. Don't forget to account for the tare weight of the bucket.

---

**If the fabric breaks with 56 pounds, it fails. Time to re-cover.**

---

Note: Where does this 56 pounds come from? **Ceconite** fabrics are manufactured to the standards of TSO-C-15d/AMS 3806C. Interestingly, this is the same standard used for Grade A Cotton, linen, or any fabric used in direct replacement. This document specifies how aircraft fabric should be manufactured, and all certified fabric used on aircraft is approved by FAA engineers based on these standards. TSO C-15d says that new aircraft fabric has to have a breaking (tensile) strength when new of at least 80 pounds per inch. (**Ceconite** is well over 102 pounds.) In service, the fabric is allowed to degrade to 70% of that 80 pounds, which works out to 56 pounds. So 56 pounds is the minimum allowable for airworthiness.

If for some reason the breaking strength is still in question, you may send the fabric to any certified testing facility to do an ASTM D5035 test on the fabric. Here at Consolidated Aircraft Coatings, 1-800-362-3490, we will do the test for you for a small fee.



# Appendix F: Star Gloss Repairs

## Repairs Are Easy in the Star Gloss System

**Star Gloss** repairs are done by cementing a patch over the damaged area with **Star-Tak** cement.

### The Rules are Simple

A hole 8 inches or *less* requires an overlap of at least 1 inch of patch material over 1 inch of old fabric. A hole 8 inches or *more* requires an overlap of at least 2 inches of patch material over 2 inches of old fabric. Larger repairs are done in exactly the same manner using a two-inch overlap. Cover seams with finishing tape.

**Let's look at a simple puncture repair using a one-inch overlap.**

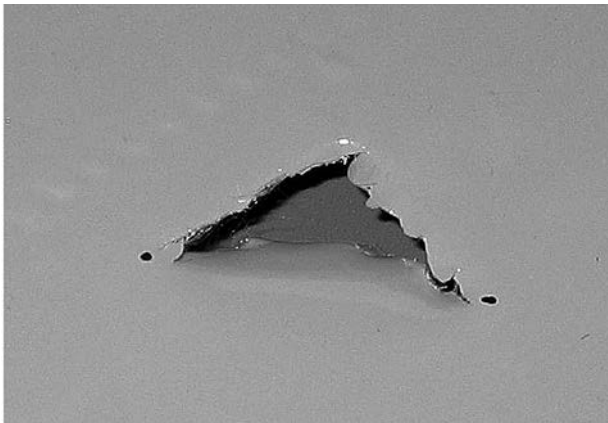

Here's a simple puncture.

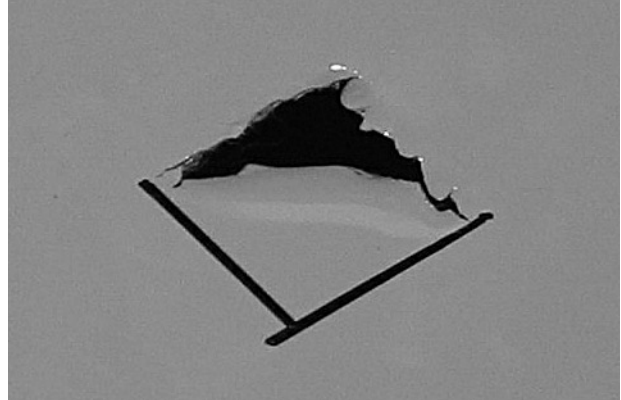
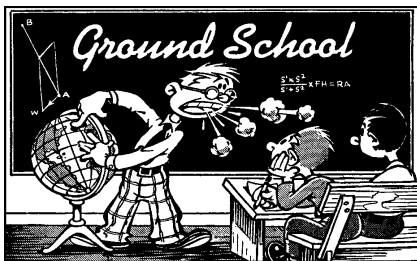

Trim the puncture and increase its size to a small square. Mark the size of the square with a small marker or Sharpie.

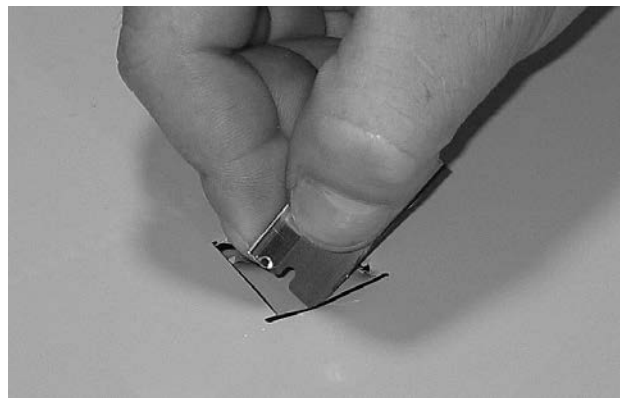

Now cut out the square with a razor blade.

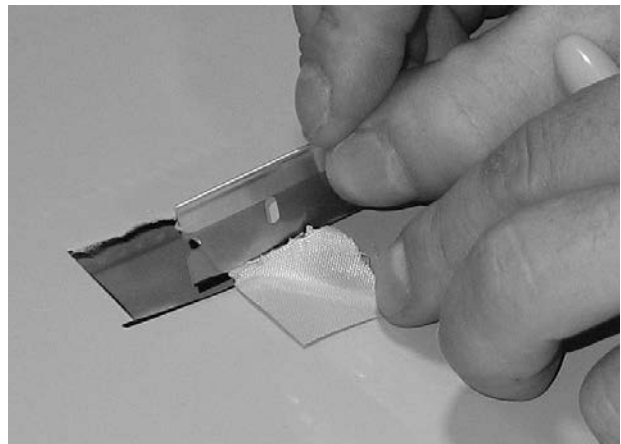

Remove the cut out.

## Appendix F - Star Gloss Repairs

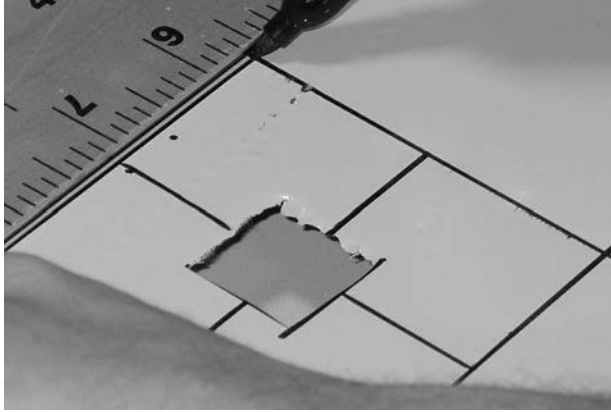

Now lay out the patch area following the rules of repairs. In this case: one inch over one inch. Think of the one-inch overlap as sort of an inch-wide picture frame around the hole.

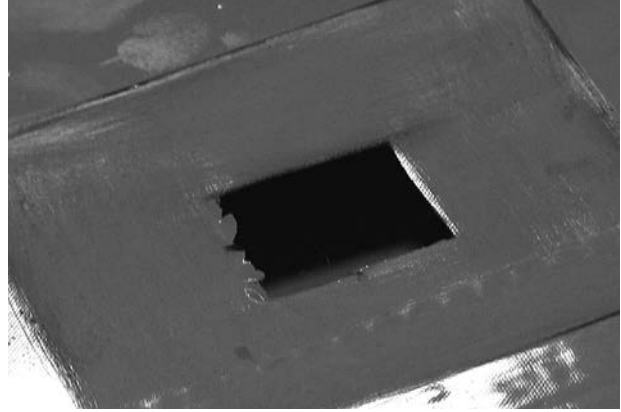

The layout area should be pretty rough when sanding is complete. This helps the bond.

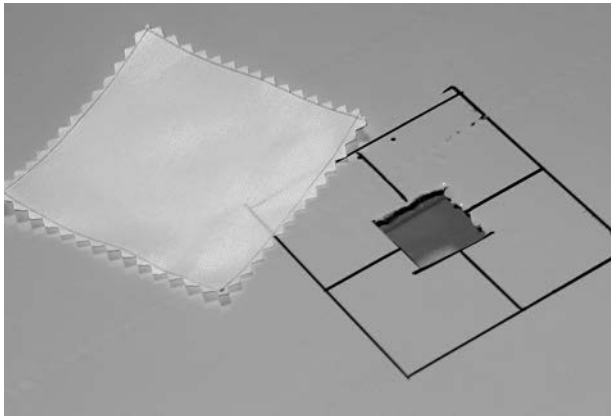

Cut out a patch from new fabric using pinking shears; the patch should be the same size as your layout.

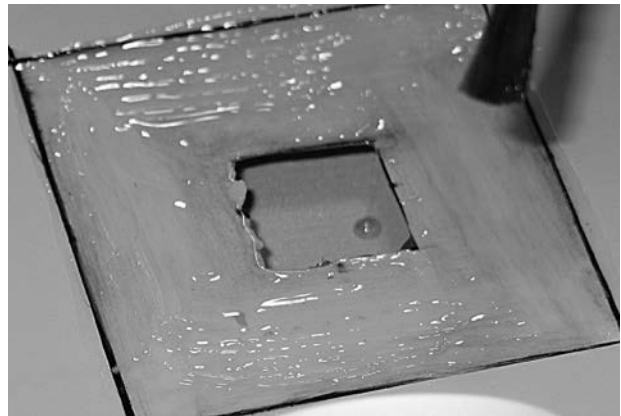

Now apply **Star-Tak** cement liberally in the layout area.

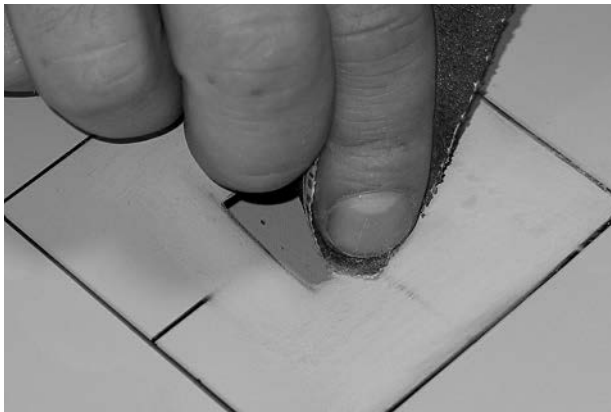

Now sand the layout area where the patch will be applied with 120-grit sandpaper.

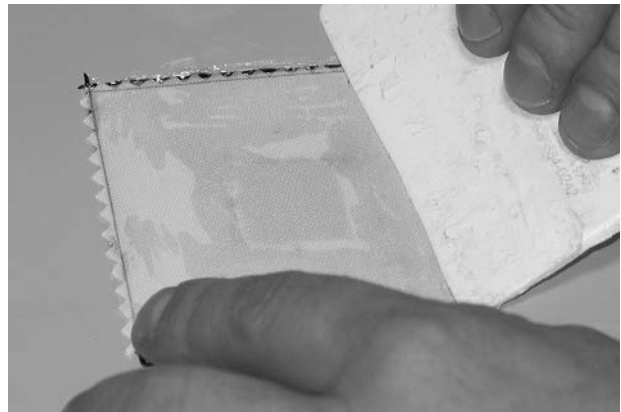

Apply the patch. Use a squeegee to smooth the **Star-Tak** under the patch.

## Appendix F – Star Gloss Repairs

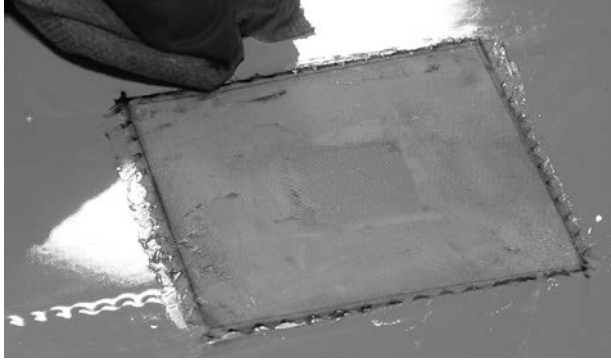

Wipe up excess **Star-Tak** with MEK.



After shrinking, brush on **Gray Sealer** thinned three to one with **Gray Sealer Reducer**.

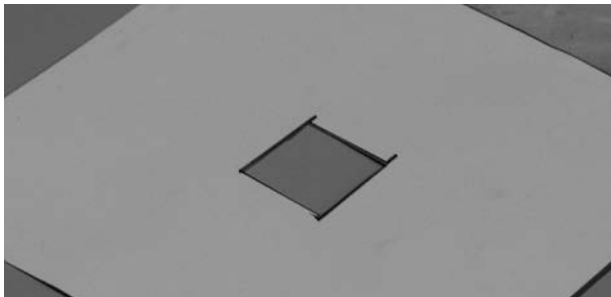

The task now is to heat-shrink the new fabric that overlies the square hole. This hole becomes a shrinking panel; when it shrinks, it also pulls up the adjacent fabric so the whole surface regains its proper tightness. First, make an ironing shield out of a piece of heavy paper or cardboard. This allows you to accurately iron the new fabric over the hole. Remember, you can't use a 350-degree iron over a cemented area, like our patch; it may loosen. The ironing shield allows you to use a 350-degree iron without loosening the patch.



After **Gray Sealer** is fully dry (at least two hours), smooth pinked edges with an iron at 225 degrees. **This is a biggie:** make sure the pinks are fully down and smooth or you will have to sand them off later.



Now use the iron to shrink the fabric over the hole, first 250 degrees, then 350.



Now spray two cross coats of **Silver Urethane Fabric Primer**, thinned three parts catalyzed primer to one part **G-4200 Thinner**.

## Appendix F – Star Gloss Repairs

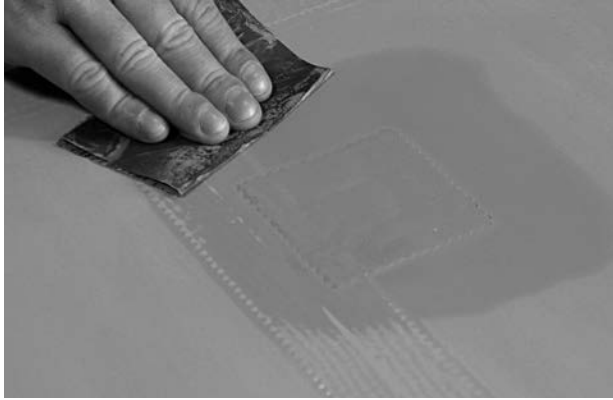

Let the two cross coats of **Silver Urethane Fabric Primer** dry at least overnight. No problem if you wait longer. Now wet sand with 320 grit until the surface is smooth.

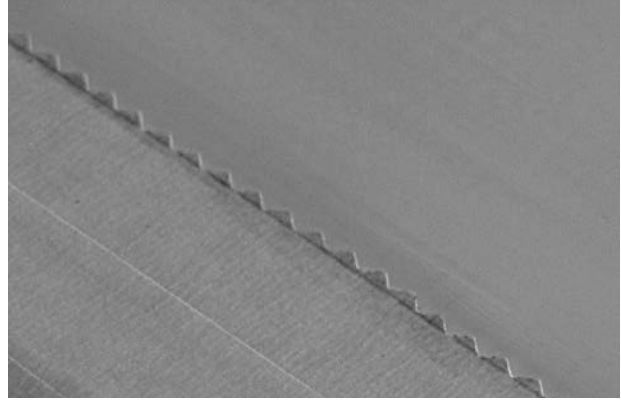

Trim the masking tape with pinking shears, then lay the pinked masking tape along side the pinks of the tape. This does a great job of hiding the painted edge.



Mask off the area you plan to paint with **Ranthane**. Don't try to spot-spray the colored **Ranthane** as you did **Silver Urethane Fabric Primer**. For best results, spray a whole panel; it is really tough to blend in shiny paint; far better to paint a large area to best hide the repair. Note that here we masked from finishing tape to finishing tape.



Now spray the first coat of **Ranthane**.

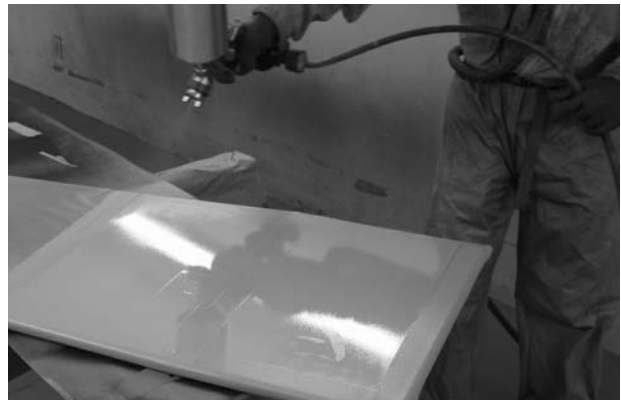

Spray the second coat after waiting at least an hour. Two hours is better.



## Large Repairs - Over 18 Inches



**Repairs over 18" long usually require repeating installation procedures used when the component was originally covered. In other words, don't rely on a huge bandaid style patch on the top of a wing or on other areas where there are excessive flight loads; use your head and follow the procedures used in original installation. On large repairs replace sufficient fabric to utilize overlaps and replace mechanical attachments. Cover any repair seam with finishing tape.**

Let's assume you ground looped your pride and joy and now need to replace an entire wingtip and a few ribs. For repairs this large the idea is to repeat the basics of fabric installation procedures explained in Chapters 4 and 5 of this manual rather than the simple puncture procedures shown in the pictures above.

For a repair as big as this, first you will need to remove enough fabric to repair the wingtip and ribs, and then replace the fabric top and bottom of the wing with overlaps on the leading and trailing edges, joining the new fabric to the old over the last undamaged rib.

### Here are the steps:

#### A. Remove the old fabric to expose the damaged area:

1. Go inboard to the last good rib; remove the tape, riblaces, and reinforcing tape over the last undamaged rib top and bottom.
2. Cut away the old fabric outboard of the last good rib, top and bottom. Cut the fabric on the outboard edge of the area

where the finishing tape was removed, leaving at least a two-inch strip of old fabric. This remaining flap is the area you will join and cement the new fabric.

#### B. Install the new fabric:

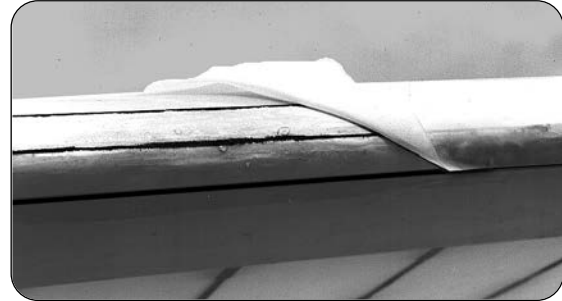

1. Cement the new top and bottom fabric as it was originally installed (a two-inch overlap over the leading edge...

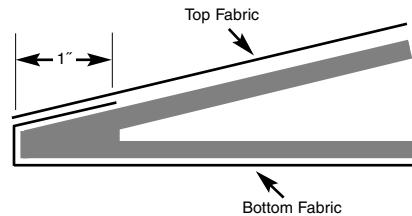

...and at least a one-inch overlap on the trailing edge).

2. In other words, install the fabric as in Chapter 5. Join the new pieces of fabric to the remaining flap of original fabric over the undamaged rib.
3. Heat-shrink as in Chapter 5.
4. Reinstall reinforcing tape, then riblace and install finishing tapes as in Chapter 5.
5. Note that by riblacing (or using other mechanical attachments) over the joined new and old fabric at the undamaged rib you will mechanically "sew" the repair together over the rib.
6. Apply coatings and paint as shown in the pictures above.

# NOTES

---

---

---

---

---

---

---

---

---

---

---

---

---

---



# Appendix G: Product Profiles

## POLYESTER FABRICS



### CECONITE 101

This heavy duty fabric is recommended for the most severe operating conditions and for very high-wing loaded aircraft. Its large filament size and high strength provide excellent rock and tear resistance. It finishes well and fills with normal applications of coatings to a smooth surface. Meets the requirements of TSO C15d.

#### RECOMMENDED AIRCRAFT:

Aerobatic and bush planes, ag aircraft, and warbirds.

### CECONITE 102

Ceconite **102** is considered our standard fabric. It is a good replacement in finish for Grade A Cotton. Recommended for all service on a wide variety of aircraft regardless of wing loading or horsepower. Meets TSO C-15d.

#### RECOMMENDED AIRCRAFT:

All classics, antiques and contemporary designs that anticipate normal on-airport operations.

### CECONITE UNCERTIFIED LIGHT

**Uncertified Light** is recommended for covering plywood surfaces on any aircraft and on any ultralight aircraft that is not certified. On certified aircraft, it is only approved for covering plywood surfaces. This fabric is unstamped.

#### RECOMMENDED AIRCRAFT:

Experimental ultralights and very light and experimental aircraft only.

## SURFACE TAPES

NOTE: ALL STYLES AND WEIGHTS OF CECONITE SURFACE TAPES ARE LEGAL FOR USE ON ANY OF THE THREE CECONITE FABRICS

### CECONITE 102 TAPES

#### PINKED EDGE C-102 TAPES



Our classic standard duty tape most generally used on Ceconite **101** and **102** fabric. All pinked **C-102** tapes come in 25-yard rolls except 2" which comes in a 50-yard roll. Offered in widths from 1" to 6".

#### STRAIGHT EDGE C-102 TAPES



Designed for Citabrias, these tapes have a heat-slit straight edge. All straight edge **C-102** tapes come in 50-yard rolls only. Offered in widths from 1" to 6".

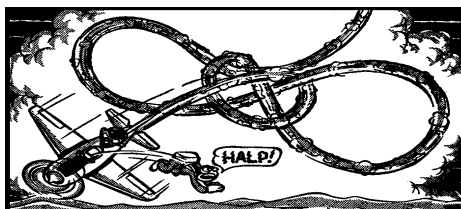

## CECONITE LIGHT TAPES

### PINKED EDGE LIGHT TAPES



These light tapes form easily around rib laces and structure. They are legal for use on any aircraft. They are offered with pinked edges only. They come in 25-yard rolls, except 2" which comes in a 50-yard roll. Offered in widths from 1" to 6".

## CECONITE BIAS TAPES

### PINKED EDGE BIAS TAPES

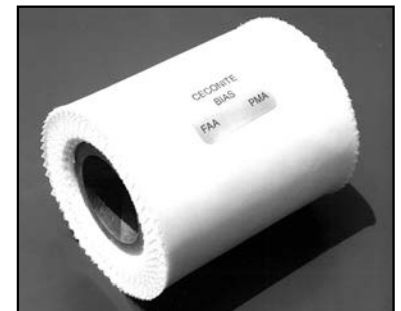

Bias tapes are designed to form around curved shapes like wing tip bows and tail-feathers without heat shrinking or notching. All have pinked edges and come in 25-yard rolls. They are offered in either 2, 3, or 4" widths. When pulled around curves, they shrink about 1/3 their normal width. In other words, a 3" bias tape will pull down to 2" wide when stretched around a curve.

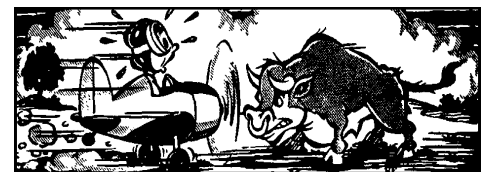

## OTHER TAPES

### POLYESTER REINFORCING TAPE



Reinforcing tapes are used to strengthen the fabric to resist cutting under rib lacing, pop rivets, or PK screws. Reinforcing tapes are applied directly over the fabric that overlies rib cap strips. Rib lacing or other mechanical attachments are then applied over or through the reinforcing tape. Reinforcing tapes are made of an extremely strong polyester twill with a sticky back for ease of application.

Reinforcing tapes are offered in  $\frac{1}{4}$ ,  $\frac{3}{8}$ , and  $\frac{1}{2}$  inch widths. When rib lacing, select the same exact width tape as your rib cap strip, no more, no less. If your ribs are wider than  $\frac{1}{2}$  inch, use two or more tapes positioned side by side. When using screws, rivets, or clips, use  $\frac{1}{2}$ -inch tape for all rib widths.

### CLOTH ANTI-CHAFE TAPE



Used to mask and smooth sharp corners and metal edges under fabric. Apply to any substructure that requires additional padding or has protrusions that could chafe the fabric. Apply before covering.

Comes in a 60-yard roll. Resistant to moisture over the years, and will not discolor.

## INTER-RIB BRACING TAPE



Polyester twill used to brace ribs before covering. See Chapter 2 for use. Comes in a roll 36 yd by  $\frac{1}{2}$ ".

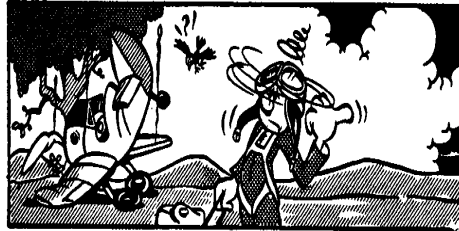

## THREADS

### POLYESTER MACHINE SEWING THREAD



10 lb tensile strength 4-ply thread. Packaged 500 yards per spool.

### POLYESTER HAND SEWING THREAD



15 lb tensile strength. 3-ply uncoated thread. Packaged 250 yards per spool.

## POLYESTER RIB LACING CORD



Two styles of lacing cord are available, both impregnated with micro-crystalline fungicidal wax.

1 - Standard round 4 ply, .035" dia., 60 lb tensile strength. Packaged 600 yards per spool.

2 - Flat braided cord, .012" thick x approximately .080" wide, 50 lb tensile strength. Recommended when the minimum rib cord protrusion is desired. Packaged 500 yards per spool.

### POLY-FIBER IRON CALIBRATION THERMOMETER



Made specifically for "taking your iron's temperature" when calibrating it. Scale has 225°, 250°, and 350° settings. Accurate  $\pm 10^\circ$ .



## STAR-TAK FABRIC CEMENT



**Use:** Star-Tak is a vinyl-based cement that is used to cement aircraft fabric to steel, aluminum, wood, or composite surfaces. It is also used to join fabric together in overlapped cemented seams. It dries to the touch in 15 to 20 minutes in normal temperatures. In two hours, it develops a bond strong enough to allow heat shrinking the fabric.

**Packaging:** Gallons, quarts.

**Mixing:** Use directly out of the can with no mixing. If the cement thickens or begins to dry in use, add MEK to bring it back to original viscosity.

**Application:** Apply directly to the surface with a one-inch brush. Lay the fabric directly into the wet cement and force the cement through the weave with protected fingers or a squeegee. Cement only 12 to 18 inches at a time to prevent the cement from drying. Cement directly to epoxy-primed metal, epoxy-varnished wood, or epoxy-primed composite surfaces.

**Shelf Life:** Guaranteed two years unopened. Heat over 100° F. can damage the cement. If the cement has been exposed to heat in storage, it will turn whiskey colored; do not use cement unless it is perfectly clear.

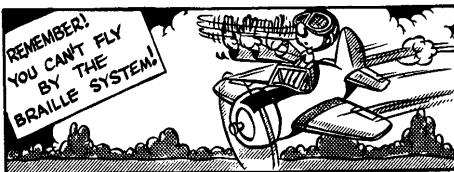

## FABRIC COATINGS

### STAR GLOSS GRAY SEALER



**Use:** Gray Sealer is used to seal Ceconite fabric prior to spraying Silver Urethane Fabric Primer. This coat prevents pinholes in the Silver Urethane Fabric Primer. Gray Sealer is also used to apply Ceconite finishing tapes. It is tinted translucent gray to help see it when applied.

**Packaging:** 5-gallon pails, gallons, quarts.

**Coverage:** Approximately 150 square feet per gallon.

**Mixing:** Use a mixing stick to blade up settled product. After hand stirring, shake on a double-action paint shaker for five minutes before use. Always insure that Gray Sealer is mixed into suspension before using.

**Thinning:** Thin three parts Gray Sealer to one part Sealer Reducer.

#### Application:

**1. To Seal Fabric:** Brush one coat on the fabric surfaces with a quality bristle or nylon brush. Put on sufficient Gray Sealer to wet the fabric with a uniform translucent coating. Runs on the inside surface of the fabric indicate that the fabric is wet on both sides, thus encapsulating the weave. Do not spray; spraying may not wet both sides of the fabric.

#### 2. Applying tapes and fabric gussets:

Apply a wet coat of Gray Sealer in the area the tape will lay. Lay the tape into the wetted area and brush with a dry brush to force the Gray Sealer through the weave of the fabric.

**Dry Time:** 20 minutes at 77° F.

**Shelf Life:** Four years in unopened storage. Avoid storage above 100° F.

### STAR GLOSS GRAY SEALER REDUCER



**Use:** Thinner for Gray Sealer.

**Packaging:** Quarts, gallons, five-gallon pails

**Mixing and Thinning:** Mix three parts Gray Sealer to one part Sealer Reducer.

**Shelf Life:** Four years, unopened in protective storage. Not affected by freezing.

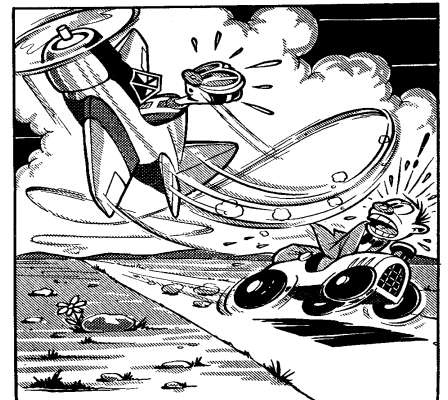

## Appendix G: Product Profiles

### STAR GLOSS SILVER URETHANE FABRIC PRIMER



**Use:** Silver Urethane Fabric Primer is a polyurethane product that serves two purposes: to build the coating over the fabric to prepare for paint, and to protect the fabric from UV radiation. Silver Primer uses a metallic-like flake additive. This proven system results in a positive metallic light block and reflection to both visible and invisible UV without relying on chemical UV light blockers.

**Packaging:** Quarts and gallons. This product is part of a three-part kit. The three components are: primer, catalyst, and thinner. All are required, and none can be substituted with other products.

**Quart Kit Components:** One quart Silver Urethane Fabric Primer, one half-pint Silver Urethane Fabric Primer Catalyst, and one quart G-4200 Ranthane Thinner. When mixed, these components yield almost two quarts of sprayable Silver Urethane Fabric Primer.

**Gallon Kit Components:** One gallon Silver Urethane Fabric Primer, one quart Silver Urethane Fabric Primer Catalyst, and one gallon G-4200 Ranthane Thinner. When mixed, these components yield almost two gallons of sprayable Silver Urethane Fabric Primer.

**Coverage:** One gallon of mixed components (almost two gallons sprayable) will yield 300 square feet. See estimated quantities in the rear of this manual.

**Mixing:** Mix four parts Silver Urethane Fabric Primer with one part Silver Urethane Fabric Primer Catalyst and stir. Allow sitting for 20 minutes induction time before use.

**Pot Life:** Six hours at 77°. This may vary with temperature and humidity. If product thickens, do not use.

**Thinning:** Thin 33% with G-4200 Ranthane Thinner. As a rule of thumb, this is three parts catalyzed Silver Urethane Fabric Primer to one part G-4200. For best results, thin 33%, then spray a vertical surface test with a moderate coat to insure that the film has no orange peel and does not run.

#### Application:



**WARNING: AS WITH ALL CATALYZED POLYURETHANES, A FRESH AIR SUPPLIED SPRAY MASK IS MANDATORY. CHARCOAL MASKS WILL NOT PROTECT FROM POLYISOCYANATES IN THE SPRAY MIST!**

Silver Urethane Fabric Primer is applied directly over Gray Sealer after all tapes have been applied and heat smoothed. For best results, wait at least 24 hours before spraying Silver Urethane Fabric Primer over Gray Sealer.

Two cross coats of Silver Primer are applied. A cross coat is two passes of the spray gun 90° to each other. Two cross coats may be applied in one day. After drying overnight, wet sand rough areas and pinked tape edges with 280-grit sandpaper. Spot sand imperfections if necessary.

**Dry Time:** 30 to 45 minutes depending on temperature and humidity. To speed up drying, use one ounce of Randolph D-7201 Ranthane Accelerator per quart of catalyzed Silver Urethane Fabric Primer.

**Shelf Life:** Two years unopened. Insure contents are fully mixed before use.

### STAR GLOSS SILVER URETHANE FABRIC PRIMER CATALYST



**Use:** Silver Urethane Fabric Primer Catalyst is the only catalyst that can be used with Silver Urethane Fabric Primer. Note that unlike other catalysts it is mixed at a four to one ratio of primer to catalyst.

**Packaging:** Quarts and half pints.

**Mixing Instructions:** See instructions above in the Silver Urethane Fabric Primer section.

**Shelf Life:** Two years in unopened container. Do not use if catalyst becomes milky or stringy.

## EPOXY PRIMERS

Epoxy primers come in two colors - white and dark green; both have identical properties and ingredients and vary only by color.

Cured epoxy primers are completely solvent resistant and are not wrinkled or lifted by fabric cements or coatings.

White is the easiest color to use under any color paint and is always a better choice for aluminum, steel, or composites that will be topcoat painted. Dark green is actually white primer tinted green for those who want to simulate the color of WWII zinc chromate on warbirds.

## Appendix G: Product Profiles

There are three parts to an epoxy primer kit: **EP-420 Primer**, **EP-430 Catalyst**, and **E-500 Thinner**; all are required and cannot be substituted.

### W-2248 EP-420W EPIBOND EPOXY PRIMER (WHITE)

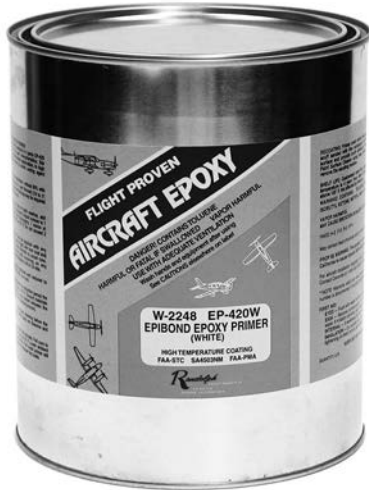

### B-6433 EP-420G RAND- O-PLATE (DARK GREEN)

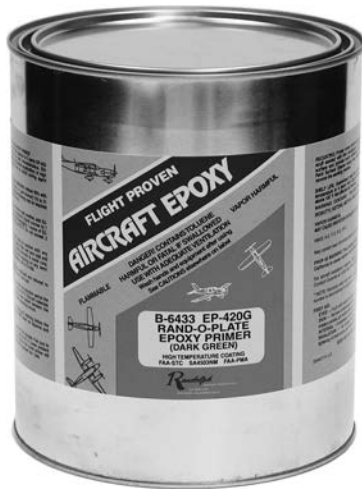

**Use:** Epoxy primer is used to coat steel, aluminum, and composite surfaces before painting. It has superior anti-corrosive properties that exceed one-part zinc chromate primers in all levels of performance. Epoxy primers may be used under **Ranthane** polyurethane and a variety of other topcoat paints. Epoxy primers may be applied directly over old one-part primers like zinc chromate or red iron oxide to provide

a solvent-proof barrier coat to protect from fabric cements and coatings.

**Packaging:** Each component of epoxy primer is sold individually or in a kit.

**Gallon Kit:** 1 gallon **Epibond** or **Rand-O-Plate Epoxy Primer**, 2 quarts **EP-430 Catalyst**, 1 gallon **E-500 Thinner**: Yield: 2½ gallons of sprayable primer when mixed.

**Quart Kit:** 1 quart **Epibond** or **Rand-O-Plate Epoxy Primer**, 1 pint **EP-430 Catalyst**, 1 quart **E-500 Thinner**. Yield: 2½ quarts of sprayable primer when mixed.

**Coverage:** One gallon of catalyzed reduced primer will cover approximately 1000 square feet with one coat.

**Mixing and Thinning:** Primer may hard settle in storage. Make sure all compacted material is mixed well with a paddle to get everything off the bottom of the can. Once paddled, agitate on a paint shaker for 5 minutes, minimum.

1. Add exactly two parts **Epoxy Primer** to one part **EP-430 Catalyst**. Stir thoroughly and allow sitting for 30 minutes induction time before application.

2. Add 50% **E-500 Epoxy Thinner** (two parts catalyzed primer to one part **E-500 Thinner**.) Additional thinning may be required in warm weather or with some spray rigs.

**Pot Life:** The sooner applied after induction, the better the service life durability. Maximum pot life is seven hours at 70°. Discard mixed primer when it increases viscosity or becomes stringy. Do not add thinner to "save" primer that has become viscous or is beginning to harden.

**Application:** Use spray equipment rated for lacquers or enamels. Spray three light coats 20 minutes apart, allowing each coat to become tacky before spraying another. Do not flood or apply thick coats as you would automotive filler primers; crawling or cratering will result. Unlike automotive primers, this aerospace primer is put on in light coats and does not dry with a chalky texture. When three coats have been applied, the result will be a

slick, hard surface that may be slightly transparent.

There is no need to paint over the top of **Epoxy Primer** when used in internal structural components like 4130 steel tube fuselages or aluminum wings. The primer itself is sufficient to act as an internal coating. Scuff up dried and cured epoxy primer with an ultrafine Scotch-Brite pad, then wipe with a cloth dampened slightly with **C-2210 Paint Cleaning Solvent** before applying topcoat paint.

**Dry/Cure Time: Epoxy Primer** will dry to the touch in 30 to 60 minutes in most conditions. **However, it takes a full seven days at 70° to chemically crosslink to full solvent resistance.** So in simplest terms, if you rush applying solvent-borne topcoat paints or fabric cement over the top of primer that has not cured for seven days, you risk wrinkling the primer. This is most probable in the hours immediately following primer application. As time passes in the seven-day crosslinking period, the primer gets more solvent resistant and the probability of wrinkling decreases. After seven days, it is imperious to all solvents.

**Cleanup:** Use **E-500**. MEK may be substituted, but does not clean tools and spray guns as well as **E-500**. Do not allow primer to dry in the gun, it will be almost impossible to remove. Clean gun as soon as you finish work.

**Shelf Life: Primer and Thinner**, 4 years in an unopened container. **EP-430 Catalyst**, two years in an unopened container.

### EP-430 EPOXY PRIMER CATALYST



## Appendix G: Product Profiles

**Use:** Catalyst for either **Epibond White Epoxy Primer** or **Rand-O-Plate Green Epoxy Primer**. See instructions under **Epoxy Primer** above.

**Packaging:** One-pint and one-quart cans.

**Shelf Life:** Two years in an unopened container. Avoid storage above 100° F.

### E-500 EPOXY THINNER

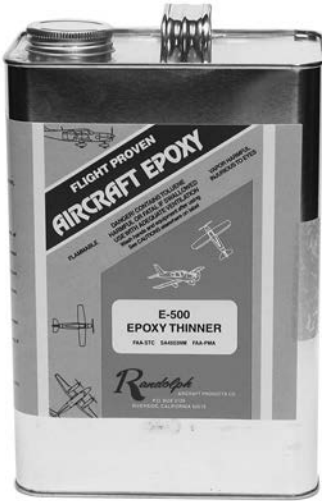

**Use:** Used to thin **Epibond** and **Rand-O-Plate Primer** as well as **EV-400 Epoxy Varnish**. Follow thinning directions on the primer and varnish cans. Do not substitute other solvents or thinners in these epoxy products.

**Packaging:** One-quart and one-gallon cans.

**Shelf Life:** Four years in unopened container.

### EX-501 EPOXY ACCELERATOR



**Use:** Accelerates the drying time of epoxy primer or varnish in cold weather.

**Packaging:** Half pints only.

**Application:**

**Epoxy Primers:** Add one to a maximum of two fluid ounces of **Accelerator** to a quart of catalyzed and thinned **Epoxy Primer**. Do not exceed two fluid ounces per quart.

**Epoxy Varnish:** Add one to a maximum of three fluid ounces to a quart of catalyzed and thinned varnish. Do not exceed three fluid ounces per quart.

### EPOXY VARNISH EV-400 EPOXY VARNISH



**Use:** **EV-400 Epoxy Varnish** is a two-part varnish that gives superior protection and performance over older one-part "spar" varnishes. **EV-400** is completely impervious to fabric cements and coatings when cured, so there is no need to use a dope-proof paint over it. **Epoxy Varnish** may be used on either old or new wood. It can be brushed or sprayed and is applied without harm directly over old varnishes to provide superior solvent resistance and protection from fabric cements and coatings.

**Packaging:** Each component (**EV-400 Epoxy Varnish**, **EV-410 Epoxy Varnish Catalyst**, and **E-500 Epoxy Thinner**) is sold individually or in a kit.

**Gallon Kit:** One gallon **EV-400 Epoxy Varnish**, two quarts **EV-410 Epoxy Varnish Catalyst**, one gallon **E-500 Epoxy Thinner**. Yield: 2½ gallons when all components are mixed.

**Quart Kit:** One quart **EV-400 Epoxy Varnish**, one pint **EV-410 Epoxy Varnish Catalyst**, one quart **E-500 Epoxy Thinner**. Yield: 2½ quarts when all components are mixed.

**Coverage:** One gallon of catalyzed and thinned varnish will cover 600 square feet with one coat.

**Mixing and Thinning:** Add exactly one part **EV-410 Epoxy Varnish Catalyst** to two parts **EV-400 Epoxy Varnish**. Measuring must be accurate for proper drying. Stir thoroughly and wait 20 minutes induction time before using.

Thin two parts catalyzed varnish with one part **E-500 Epoxy Thinner**.

**Pot life:** The sooner applied after induction, the better the service life durability. Maximum pot life is seven hours at 70°. Discard mixed primer when it increases in viscosity or becomes stringy. Do not add thinner to "save" varnish that has become viscous or has begun to harden.

**Application:** **EV-400 Epoxy Varnish** may be brushed or sprayed. The first coat on new wood should be brushed; remaining coats should be sprayed with equipment rated for lacquers or enamels. Spray three coats at least 20 minutes apart, allowing the surface to become tacky between coats. Final film thickness should be one to two mils when dried. Flooding on coats will result in crawling or cratering.

**Dry/Cure Time:** **Epoxy Varnish** will dry to the touch in 30 to 60 minutes in most conditions. **However, it takes a full seven days at 70° to chemically crosslink to a full solvent resistance.** So in simplest terms, if you rush applying fabric cement or a solvent-borne coating over the top of varnish that has not cured for seven days, you risk wrinkling the varnish. This is most probable in the early hours following varnish application. As time passes in the seven-day crosslinking period, the primer gets more solvent resistant and the possibility of wrinkling decreases.

## Appendix G: Product Profiles

**Clean up:** Use **E-500**. MEK may be substituted, but may not clean tools and spray guns as well as **E-500**. Do not allow varnish to dry in the gun; it will be almost impossible to remove.

**Shelf Life:** Guaranteed unopened shelf life is four years from date of manufacture. Avoid storage above 100° F.

### EV-410 EPOXY VARNISH CATALYST



**Use:** Catalyst for **EV-400 Epoxy Varnish** only. Add one part **EV-410 Catalyst** to two parts **EV-400**.

**Packaging:** One pint and one quart cans.

**Shelf Life:** Guaranteed two years unopened. Avoid storage above 100° F.

### RANTHANE POLYURETHANE



**Use:** **Ranthane** is a high-solids, flexible, two-part polyurethane that is FAA approved for use on **Ceconite** fabric. Other poly-urethanes are not approved on the **Ceconite STC**. Although extremely flexible, **Ranthane** is also optimized for use on primed aluminum, steel, or composite surfaces. **Ranthane** is offered in 50 colors as presented on **Randolph Color Card 2004**. **Ranthane** has three separately packaged components that are mixed before application. All three components are required and cannot be substituted: **Ranthane** polyurethane paint, **AU-CAT-2X1 Catalyst**, and **G-4200 Ranthane Thinner**.

**Packaging:** Gallons and quarts. Required components are as follows:

**Gallon Components:** One gallon **Ranthane** polyurethane paint, two quarts **AU-CAT-2X1 Catalyst**, one gallon **G-4200 Ranthane Thinner**. These components will yield over two gallons of sprayable **Ranthane**.

**Quart Components:** One quart **Ranthane** polyurethane paint, one pint **AU-CAT-2X1 Catalyst**, one quart **G-4200 Ranthane Thinner**. These components will yield over two quarts of sprayable **Ranthane**.

**Coverage:** One gallon of mixed components (two gallons sprayable) will yield 300 square feet with one coat. See estimated quantities in the rear of this manual.

**Mixing:** Mix two parts **Ranthane** with one part **AU-CAT-2X1** and stir. Allow to sit for 20 minutes induction time before use.

**Pot Life:** Six hours depending on temperature and humidity.

**Thinning:** Thin 33% with **G-4200 Ranthane Thinner**. As a rule of thumb, this is about three parts catalyzed **Ranthane** to one part **G-4200 Ranthane Thinner**. For best results, thin 33%, then spray a test area to insure that the film has no orange peel. If necessary, you can add up to three parts paint to two parts thinner.

**Application:** See full text on spraying in Chapter 8, Spraying **Ranthane Topcoat**.

**WARNING: AS WITH ALL CATALYZED POLYURETHANES, A FRESH-AIR SUPPLIED SPRAY MASK IS MANDATORY. CHARCOAL MASKS WILL NOT PROTECT FROM POLYISOCYANATES IN THE SPRAY MIST!**



For best results, wait as long as possible before spraying **Ranthane** over primers. When spraying over **Silver Urethane Fabric Primer** on fabric surfaces, wait a week if possible before spraying **Ranthane**. It takes a full week for any polyurethane to develop full solvent resistance and curing. Waiting a week insures that the **Silver Urethane Fabric Primer** is fully cured, which is different from drying. When cured fully, **Ranthane** topcoat paint flows out beautifully over **Silver Urethane Fabric Primer** and the resulting fabric surface will be smooth with the highest possible gloss.

Lightly scuff the cured **Silver Urethane Fabric Primer** (or epoxy primer if spraying metal components) with an ultrafine Scotch-Brite pad before spraying **Ranthane** color.

Before committing to spraying a whole component, spray a vertical test area, hopefully not on your airplane. If orange peel results, add more **Ranthane Thinner**. If the test area results in runs, spray less. Spray a mist coat; allow this coat to dry until tacky. Follow with a moderate coat, wet enough for coverage and color, but not heavy enough to run. Wait one hour and spray a third wet coat. You may need a fourth. If you wait more than seven days between coats, lightly scuff the surface with an ultrafine Scotch-Brite pad.

**Shelf Life:** Four years unopened. Insure contents are fully mixed before use.

## Appendix G: Product Profiles

### AU-CAT-2X1 RANTHANE CATALYST



**Use:** AU-CAT-2X1 is the only catalyst approved for **Ranthane**. Other products cannot be substituted. See mixing instructions in the **Ranthane** section above.

**Packaging:** Pints and quarts only.

**Shelf Life:** Two years unopened. Do not use if the catalyst becomes milky or stringy. **Catalyst** reacts with humidity; once opened, it may react in contact with any moisture.

### G-4200 THINNER FOR RANTHANE



**Use:** G-4200 Thinner is a special blend of solvents specifically formulated for use with **Ranthane** polyurethane paint. Other products cannot be substituted. See mixing instructions in the **Ranthane** section above.

**Packaging:** Quarts and gallons.

**Shelf Life:** Unlimited in closed containers.

### D-7201 RANTHANE ACCELERATOR



**Use:** This product accelerates the drying time of **Ranthane**. Used to speed drying in cooler spraying temperatures (60s), or to accelerate drying time when airborne dirt contamination is a problem.

**Packaging:** Quarts.

**Shelf Life:** Four years unopened.

**Mixing:** Add AU-CAT-2X1 Catalyst to **Ranthane** before adding D-7201 Accelerator. Use up to four fl oz per catalyzed gallon (one fl oz per catalyzed quart). Finally, add G-4200 Thinner as instructed above.

### FLATTENER



**Use:** Flattener is a liquid product with silica flattener added. It is used to reduce the gloss of **Ranthane**. Adding flattener in increasing amounts can result in semi-

gloss or full military flat depending on the percentage added. Flattening is not an exact science; it is always best to spray a sample then let it dry to insure you are achieving the flatness desired.

**Packaging:** Quarts and pints.

**Mixing:** Flattener must be stirred and shaken regularly to insure that all the silica is in suspension.

**Application:**

First, get bigger containers for mixing. Since **Flattener** always increases the volume of the paint, if you plan on flattening a whole quart or gallon at one time, you will need empty cans or containers big enough to hold the flattened product. For example, if you are going to flatten a quart of **Ranthane**, you will need an empty gallon can with a lid if you plan to store it after flattening.

Second, always do a test spray to insure you are getting the level of flatness you desire. Flatten a small amount, spray and let it dry. Do this before you commit to painting your airplane. Adjust the amount of **Flattener** if necessary; again, flattening is not an exact science. **Test first!**

**To Flatten Ranthane to Semi-gloss:**

1. Add four parts paint to one part **Flattener** (eight fluid ounces **Flattener** per quart of paint).
2. Catalyze this flattened mixture normally (two parts flattened paint to one part catalyst).
3. Thin the catalyzed, flattened paint normally (three parts catalyzed paint to one part G-4200 Thinner).

**NOTE: YOU'LL NEED EXTRA AU-CAT2X1 CATALYST.** Since the flattened paint yields more sprayable product, you will need some extra catalyst. In this case, each quart of semi-gloss flattened **Ranthane** will need an extra pint of catalyst; each gallon will also need an extra pint of catalyst.

**To Flatten Ranthane to Full Flat:**

1. Add two parts paint to one part **Flattener** (16 fluid ounces of **Flattener** per quart of paint).
2. Catalyze this flattened mixture normally (two parts flattened paint to one part catalyst).



## Appendix G: Product Profiles

3. Thin the catalyzed, flattened paint normally (three parts catalyzed paint to one part **G-4200 Thinner**).

**NOTE: YOU WILL NEED EXTRA AU-CAT2X1 CATALYST.** Since the flattened paint yields more sprayable product, you will need some extra catalyst. In this case, each quart of full-flat **Ranthane** will need an extra pint of catalyst, and each gallon of full-flat **Ranthane** will need an extra quart of catalyst.

If after testing your flattened **Ranthane** you decide to add more flattener than the above ratios, just remember that you will need to add additional catalyst to compensate for the increased ounces of flattened **Ranthane**.

**Shelf Life:** Four years unopened.

## C-2210 PAINT SURFACE CLEANER



**Use:** A mild solvent cleaner used to clean surfaces before spray painting.

**Packaging:** One-quart and one-gallon cans.

**Shelf Life:** Unlimited in unopened cans.

**Application:**

**CAUTION!** Insure parts are well grounded, particularly in the presence of high static electricity. If the weather is such that you are getting shocked on doorknobs, ground the part with a proper grounding cord;

**aggressive rubbing can cause enough static electricity to ignite fumes.**

Use sparingly on a barely damp clean rag or paper towel. Do not soak the rag; insure it is only slightly damp. Wipe gently over surfaces that are about to be painted or between coats if you suspect contamination on the surface. If a wet film results, you are using too much. Follow with a dry clean rag or paper towel. Wait at least two hours for all solvents to evaporate; again, use only sparingly as a cleaner. If you put it on wet and immediately spray, the wet **C-2210** can harm the film.

### MANUFACTURING DATE CODES

The manufacturing dates of all liquid products are indicated on the labels. The first two digits are the year, the third and fourth digits are the month, and the last three digits indicate the production batch number for that month.

### PRODUCT WARRANTY and LIABILITY

Warranty limited to the replacement of materials only. Since we have no control over the application of our products, we disclaim any guarantee of performance.



# NOTES

---

---

---

---

---

---

---

---

---

---

---

---

---

United States Of America  
Department of Transportation - Federal Aviation Administration.

# Supplemental Type Certificate

*Number* SA4503NM

*This Certificate issued to* Ceconite Division of Poly-Fiber, Inc. (mailing address)  
4343 Fort Drive or P.O. Box 3129  
Riverside, California 92509-3129 Riverside, California 92519

*certifies that the change in the type design for the following product with the limitations and conditions therefor as specified hereon meets the airworthiness requirements of Part \* of the \* Regulations*

*Original Product Type Certificate Number :* \* \* See attached FAA Approved Model List (AML) No. SA4503NM for list of approved aircraft models and applicable airworthiness regulations  
*Make :* \*  
*Model :* \*

*Description of Type Design Change* Remove original cloth covering and install Ceconite covering material in accordance with either Procedure Manual 101 for the Ceconite Aircraft Covering Process, dated August 1997, or Star Gloss Procedure Manual STC SA4503NM Instructions for Continued Airworthiness, dated May 2010, or later FAA approved revisions.

*Limitations and Conditions:* The approval for this modification applies to the aircraft models on the attached FAA Approved Model List No. SA4503NM only. This installation should not be incorporated in any aircraft unless it is determined that the interrelationship between this installation and any previously approved configuration will not introduce any adverse effect upon the airworthiness of the aircraft. This modification was determined not to increase the noise level and was not considered an "acoustic change" as defined in section 21.93(b), Amendment 21-71 of the Federal Aviation Regulations.

*This certificate and the supporting data which is the basis for approval shall remain in effect until surrendered, suspended, revoked or a termination date is otherwise established by the Administrator of the Federal Aviation Administration.*

*Date of application :* June 6, 1988

*Date reissued :* November 13, 1997

*Date of issuance :* January 3, 2000

*Date amended :* June 29, 2010



*By direction of the Administrator*

(Signature)

Manager, Airframe Branch  
Los Angeles Aircraft Certification Office

(Title)

*Any alteration of this certificate is punishable by a fine of not exceeding \$1,000, or imprisonment not exceeding 3 years, or both.*

# NOTES

---

---

---

---

---

---

---

---

---

---

---

---

---

---

---

**FEDERAL AVIATION ADMINISTRATION - PARTS MANUFACTURER APPROVAL**

**Ceconite**  
**4343 Fort Drive**  
**P.O Box 3129**  
**Riverside, CA 92519-3129**

**PMA NO. PQ0318NM**  
**SUPPLEMENT NO. 1**  
**DATE: January 7, 1997**  
**AMENDED: April 28, 2003**

<u>PART NAME</u>	<u>PART NUMBER</u>	<u>APPROVED REPLACEMENT FOR PART NUMBER</u>	<u>APPROVAL BASIS AND APPROVED DESIGN DATA</u>	<u>MAKE ELEGIBILITY</u>	<u>MODEL ELEGIBILITY</u>
Ceconite Aircraft Covering Process	As listed in Ceconite Procedures Manual 101 dtd: 8/97	Modification Part	STC SA4503NM <u>Dwg:</u> Ceconite Procedure Manual 101 <u>Rev:</u> None <u>Dtd:</u> August 1997	Per Approved Model List (AML): SA4503NM	Per Approved Model List (AML): SA4503NM

or later FAA approved revision(s)

-----End of Listing-----

**Note: Minor design changes (reference 14 CFR part 21 §§ 21.93 and 21.95) must be submitted in a manner as determined by the ACO. Major design changes (reference 14 CFR part 21 §§ 21.93 and 21.97) to drawings and specifications are to be handled in the same manner as that for an original FAA-PMA.**

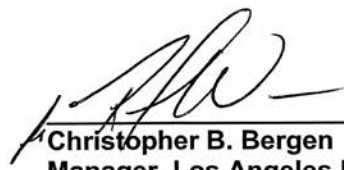
  
 \_\_\_\_\_  
**Christopher B. Bergen**  
**Manager, Los Angeles Manufacturing**  
**Inspection District Office**

# NOTES

---

---

---

---

---

---

---

---

---

---

---

---

---

---

---

---

---

---

---

---

---

---

---

If an aircraft is not listed on the Ceconite Approved Model List (AML), it may be added as follows:

1. The mechanic who did the work should complete this form and sign it.
2. Send the form to Ceconite Division of Poly-Fiber, P. O. Box 3129, Riverside, CA 92519.
3. Ceconite will acknowledge receipt back to you and submit the Installation Report for your aircraft to the FAA Los Angeles Aircraft Certification Office/ANM-120L, 3960 Paramount Blvd., Lakewood, CA 90712-4137 (phone 562-627-5232). Your aircraft will be added to the published Approved Model List when the Ceconite Procedure Manual is revised and reprinted.

---

## **CECONITE/STAR GLOSS INSTALLATION REPORT**

I certify that fabric-covered surfaces of the following aircraft have been recovered in accordance with the Star Gloss Aircraft Covering Process Procedure Manual STC SA4503NM Instructions for Continued Airworthiness.

Aircraft Make: \_\_\_\_\_

Aircraft Model: \_\_\_\_\_

Aircraft Type Certificate Number: \_\_\_\_\_

Date of Installation Completion: \_\_\_\_\_

Components Recovered: \_\_\_\_\_

---

Date of Star Gloss Procedure Manual: \_\_\_\_\_

Signed: \_\_\_\_\_  
(Signature & Date)

\_\_\_\_\_  
(Printed Name)

\_\_\_\_\_  
(Address)

\_\_\_\_\_  
(Phone)

\_\_\_\_\_  
(Email Address)

# NOTES

---

---

---

---

---

---

---

---

---

---

---

---

---



# FAA Approved Model List (AML) No. SA4503NM

## The Ceconite STC for Installing Fabric Covering

Issue Date: June 6, 1988

Note: Entries shown in bold are either new or were revised since the previous Approved Model List, dated January 2003.

Item No.	Aircraft Make	Model	Original Type Certificate	Components	AML Amend.
1	Aeronca	C-2 Standard, C-2 Scout, PC-2	ATC 351	All fabric covered components	
2	Aeronca (American Champion / Bellanca / Trytek)	C-3, PC-3	A-396	All fabric covered components	
3	Aeronca (American Champion / Bellanca / Trytek / Gores)	K, KS	A-634	All fabric covered components	1/1/2003
4	Aeronca	LC, LCS	ATC 614	All fabric covered components	1/1/2003
5	Aeronca (American Champion / Bellanca / Trytek)	O-58A (Army L-3A), O-58B (Army L-3B, L-3C), SO-58B	A-751	All fabric covered components	1/1/2003
6	Aeronca (Gores)	50-C, 65-C, 65-CA (Army L-3F), S-50-C, S-65-C, S-65-CA, KCA	A-675	All fabric covered components	1/1/2003
7	Aeronca (Trytek/Gores)	50-L, 50-LA, 65-LA, 65-LB (Army L-3G)	A-702	All fabric covered components	
8	Aeronca (American Champion / Bellanca / Trytek)	50-TC, 60-TF, 65-TC (Army L-3J), 65-TF, 50-TL, 65-TL, 65-TAC (Army L-3E), 65-TAF (Army L-3D), 65-TAL, YO-58 (Army L-3)	A-728	All fabric covered components	1/1/2003
9	Aeronca (Bellanca / American Champion)	Champion 7AC, 7ACA, 7AC, 7BCM (Army L-16A), 7CCM (Army L-16B), 77CCM, 7DC, 77DC, 7EC, 77EC, 7ECA, 7FC, 7GC, 7GCA, 7GCAA, 7GCB, 7GGBA, 7GCBC, 7HC, 7JC, 7KC, 7KCAB	A-759	All fabric covered components	1/1/2003
10	American Champion (Bellanca)	8KCAB, 8GCBC	A21CE	All fabric covered components	1/1/2003
11	Aeronca (American Champion / Bellanca / Trytek)	Chief 11AC, S11AC, 11BC, S11BC	A-761	All fabric covered components	
12	American Champion (Aeronca / Bellanca / Trytek)	Super Chief 11CC, S11CC	A-796	All fabric covered components	
13	Aeronca (Rogers / Mitchell)	Sedan 15AC, S15AC	A-802	All fabric covered components	

## FAA Approved Model List (AML) No. SA4503NM

Item No.	Aircraft Make	Model	Original Type Certificate	Components	AML Amend.
14	Aerotechnik s.r.o.	L13 SEH VIVAT Glider	G72EU	All fabric covered components	6/1/2008
15	Aetna Aircraft	2SA	TC 733	All fabric covered components	1/1/2003
16	Air Tractor, Inc.	AT300, AT301, AT302, AT400, AT400A	A9SW	All fabric covered components	1/1/2003
17	American (Roos)	American Eagle A-1 or 101	ATC 17	All fabric covered components	
18	American (Roos)	Eaglet B-31	ATC-450	All fabric covered components	1/1/2003
19	American Airplane & Engine Corp.	Pilgrim 100B	ATC 470	All fabric covered components	6/1/2008
20	American Blimp Corp.	A-1-50	S00002SE	All fabric covered components	6/1/2008
21	Arrow Aircraft & Motors Corp.	Arrow Sport	ATC 115 / TC 2-110	All fabric covered components	
22	Aviat (Sky / Christen / White)	A-1	A22NM	All fabric covered components	1/1/2003
23	Ayres (Rockwell Commander)	Snow S-2B, S-2C, 600-S-2C	2A7	All fabric covered components	
24	Ayres (Rockwell)	Thrush 600 S-2D, S-2R	A3SW	All fabric covered components	1/1/2003
25	Ayres (Rockwell)	Commander 600 S2D, 600 S2R	A4SW	All fabric covered components	1/1/2003
26	Beech	C18S (Army C-45, -45A, UC-45B, -45F, AT-7, -7A, -7B, -7C; Navy JRB-1, -2, -3, -4, SNB-2, -2C, -3)	A-757	All fabric covered components	1/1/2003
27	Beech	D17S (Army UC-43, -43B; Navy GB-1, -2), SD17S	A-649	All fabric covered components	
28	Beech	D17A (Army UC-43F)	TC 713	All fabric covered components	
29	Beech	D17R (Army UC-43A)	TC 638	All fabric covered components	
30	Beech	D18C, D18S, E18S, E18S-9700, G18S, H18, C-45G, TC-45G, C-45H, TC-45H, TC-45J (SNB-5), JRB-6	A-765	All fabric covered components	
31	Beech	E17B (Army UC-43D)	TC 641	All fabric covered components	
32	Beech	F17D (Army UC-43C)	TC 689	All fabric covered components	
33	Beech	Army AT-11, Navy SNB-1	A-2-582	All fabric covered components	
34	Bell Helicopter	47D1	H-1	All fabric covered components	

## FAA Approved Model List (AML) No. SA4503NM

Item No.	Aircraft Make	Model	Original Type Certificate	Components	AML Amend.
35	Bellanca (Aeronca / American Champion)	14-9	TC 716	All fabric covered components	6/1/2008
36	Bellanca (Aeronca / American Champion)	14-12F-3	TC 745	All fabric covered components	
37	Bellanca (Aeronca / American Champion)	14-13, 14-13-2, -3, -3W	A-773	All fabric covered components	
38	Bellanca	Cruisemaster 14-19, -19-2, -3, -3A, 17-30, 17-31, 17-31TC	1A3	All fabric covered components	1/1/2003
39	Bellanca	17-30A, 17-31A, 17-31ATC	A18CE	All fabric covered components	1/1/2003
40	Bellanca	Eagle DW-1	A4NW	All fabric covered components	1/1/2003
41	Bellanca (Aeronca / American Champion)	CH-300 Pacemaker	ATC 129	All fabric covered components	
42	Blanik (LET Aeronautical Works)	L-13 Glider	G24EU	All fabric covered components	
43	Blanik (LET Aeronautical Works)	L-23 Super-Blanik Glider	G60EU	All fabric covered components	1/1/2003
44	Boeing	Army B-17F, B-17G	LTC-1	All fabric covered components	
45	Boeing	377	A-812	All fabric covered components	
46	Brunner-Winkle (Perth-Amboy)	Bird BK	ATC 239	All fabric covered components	
47	Brunner-Winkle (Bird / Perth-Amboy)	Bird BW	ATC 382	All fabric covered components	1/1/2003
48	Brunner-Winkle (Bird / Perth-Amboy)	Bird CK	ATC 388	All fabric covered components	1/1/2003
49	Buhl	Flying Bull Pup LA-1	ATC 405	All fabric covered components	
50	Callair (Intermountain / Aero Commander)	A, A-2, A-3, A-4, A-5, A-5T, A-6, A-7, A-7T, A-9, A-9B	A-758	All fabric covered components	1/1/2003
51	Callair (Intermountain / Aero Commander)	B-1A	A8WE	All fabric covered components	1/1/2003
52	Cessna	120, 140	A-768	All fabric covered components	
53	Cessna	C-145, C-165 (Army UC-94)	A-701	All fabric covered components	
54	Cessna	170	A-799	All fabric covered components	
55	Cessna	T-50 (Army AT-17 & UC-78 Series, Navy JRC-1)	A-722	All fabric covered components	

## FAA Approved Model List (AML) No. SA4503NM

Item No.	Aircraft Make	Model	Original Type Certificate	Components	AML Amend.
56	Chase (Roberts)	YC-122C	AR-25	All fabric covered components	
57	Command-Aire	3-C-3 Trainer	ATC 150	All fabric covered components	
58	Commonwealth (see Rearwin)				
59	Consolidated-Vultee (General Dynamics)	PBY-5 (Army OA-10), PBY-5A (Army OA-10A)	TC 2-548	All fabric covered components	
60	Consolidated-Vultee (General Dynamics)	PBY-6A (Convair)	TC AR-22	All fabric covered components	
61	Convair (Consolidated-Vultee / General Dynamics)	Army L-13A	TC AR-10	All fabric covered components	
63	Consolidated-Vultee (General Dynamics)	BT-13, -13A (Navy SNV-1), -13B (Navy SNV-2), -15	A-2-571	All fabric covered components	
63	Consolidated-Vultee (General Dynamics)	P4Y-2 (Convair Privateer)	TC AR-29	All fabric covered components	
64	Consolidated-Vultee (General Dynamics)	28-5ACF Catalina	TC 785	All fabric covered components	
<b>65</b>	<b>Culver (Superior)</b>	<b>Cadet LFA</b>	<b>A-730</b>	<b>All fabric covered components</b>	<b>6/1/2008</b>
66	Culver (Superior)	V, V2	A-778	All fabric covered components	1/1/2003
67	Culver (Superior)	Army PQ-14A, -14B, YPC-14A, -14B; Navy TD2C-1	LTC-28	All fabric covered components	1/1/2003
68	Curtiss-Wright (Reed)	P-40L, P-40N	TCS LTC-18	All fabric covered components	1/1/2003
69	Curtiss-Wright	C-46A, C-46D	A-772, A-789, 3A2	All fabric covered components	1/1/2003
70	Curtiss-Wright	C-46E	A-772, A-786	All fabric covered components	1/1/2003
71	Curtiss-Wright	C-46R	3A2	All fabric covered components	1/1/2003
<b>72</b>	<b>Curtiss-Wright</b>	<b>Robin C-2</b>	<b>ATC 144</b>	<b>All fabric covered components</b>	<b>6/1/2008</b>
73	Curtiss-Wright	Robin J-1, J-1 Deluxe	ATC 220	All fabric covered components	
74	Curtiss-Wright	CW-1	ATC-397	All fabric covered components	1/1/2003
75	Dart	G	TC 674	All fabric covered components	
76	Davis	D-1-K	ATC 272	All fabric covered components	1/1/2003
77	Davis	D-1-W	TC 2-394	All fabric covered components	
78	de Havilland (Cliff Robertson)	DH 82A Tiger Moth	A8EU	All fabric covered components	

# FAA Approved Model List (AML) No. SA4503NM

Item No.	Aircraft Make	Model	Original Type Certificate	Components	AML Amend.
79	de Havilland	104 Dove Series 1A, 2A, 5A, 5BA, 6A, 6BA, 7A, 7AXC, 8A, 8AXC	A-807	All fabric covered components	1/1/2003
80	de Havilland	DHC-1B-2 Chipmunk	A26NM	All fabric covered components	1/1/2003
81	de Havilland (Rust)	DHC1 Chipmunk 22A	A44EU	All fabric covered components	
82	Dornier-Werke	Do 28 A-1	7A13	All fabric covered components	1/1/2003
83	McDonnell Douglas	DC-3-G102, DC3-G102A (Army C-49E, -50, -50A, -50B, -50C, -50D, -51), DC3-G103A, DC3-G202A (Army C-49, -49A, -49B, -49C, -49D, -49J, -49K, Navy R4D-2)	A-618	All fabric covered components	1/1/2003
84	McDonnell Douglas	DC3A-SCG,-SC3G,-S1CG,-S1C3G (Army C-41, C-41A, C-48,-48A,-52,-52A,-52B,-52C,-53,-53B,-53C,-53D,-68; Navy R4D-3,-4); DC3A-S4C4G; DC3C-SC3G,-S1C3G,-S4C4G (Army C-47,-47A; Navy R4D-1,-5); DC3C-R-1830-90C (Army C-47B; Navy R4D-6); DC3D-R-1830-90C (Army C-117A)	A-669	All fabric covered components	
85	Douglas	R4D-8	6A2	All fabric covered components	
86	Douglas (Seaboard)	Army A-24B, Navy SBD-5	L-4	All fabric covered components	
87	Douglas	A-26B (Army), A-26C (Army)	TCS L-3	All fabric covered components	
88	McDonnell Douglas	C-54-DC (Army C-54, Navy R5D); C54A-DC (Army C-54A, Navy R5D-1); C54B-DC (Army C-54B, Navy R5D-2); C54D-DC (Army C-54-D, Navy R5D-3); C54E-DC (Army C-54E, Navy R5D-4); C54G-DC (Army C-54G, Navy R5D-5), DC-4	A-762	All fabric covered components	
89	McDonnell Douglas	DC-6 (YC-112A)	A-781	All fabric covered components	
90	McDonnell Douglas	DC-6A (Navy R6D-1, USAF C-118A)	6A3	All fabric covered components	
91	McDonnell Douglas	DC-6B (Navy R6D-1Z)	6A4	All fabric covered components	
92	McDonnell Douglas	DC7B	4A10	All fabric covered components	
93	<b>Duramold Aircraft Corp.</b>	<b>F-46A</b>	<b>TC 2-545</b>	<b>All fabric covered components</b>	<b>6/1/2008</b>
94	Emair (Murryair)	MA-1, MA-1B	A6PC	All fabric covered components	1/1/2003
95	Ercoupe	415-C, -CD	A-718	All fabric covered components	
96	Ercoupe	415-D, -E, -G	A-787	All fabric covered components	
97	Extra Flugseagbau	EA-300/200	A67EU	All fabric covered components	1/1/2003

## FAA Approved Model List (AML) No. SA4503NM

Item No.	Aircraft Make	Model	Original Type Certificate	Components	AML Amend.
98	Fairchild	KR-21	ATC 215	All fabric covered components	
99	Fairchild	KR-31	ATC 19	All fabric covered components	
100	Fairchild Hiller	M-62A (Army PT-19, -19A, -19A-AE, -19A-SL, -19B, -19B-AE); M-62A-3 or -4 (Army PT-26, -26A, -26B); M-62B, -62C (Army PT-23, -23-AE, -23-HO, -23-SL, -23A, -23A-SL)	A-724	All fabric covered components	
101	Fairchild	22 C7G	ATC 564	All fabric covered components	
102	Fairchild	24 C8	ATC 475	All fabric covered components	1/1/2003
103	Fairchild	24 C8C, C8CS	A-535	All fabric covered components	1/1/2003
104	Fairchild	24 C8E and 24 C8ES	ATC 600	All fabric covered components	1/1/2003
105	Fairchild	24G (Army UC-61H)	ATC 633	All fabric covered components	
106	Fairchild	24H	ATC 632	All fabric covered components	1/1/2003
107	Fairchild	24J (Army UC-61B), 24JS	TC 663	All fabric covered components	
108	Fairchild	24R9 (Army UC-61C), 24R9S, 24R40 (Army UC-86), 24R40S, 24R46, 24R46A (Army UC-61K), 24R46S	A-706	All fabric covered components	1/1/2003
109	Fairchild (Steward)	C-82A Jet Packet	AR-15	All fabric covered components	
110	Fairchild	F-45 (Army UC-80)	TC 603	All fabric covered components	
111	Fleet (Brewster)	Fleet 1	ATC 122	All fabric covered components	
112	Fleet (Brewster)	Fleet 2	ATC 131	All fabric covered components	
113	Fleet (Brewster)	Fleet 7, 7-C, 7 Deluxe, 10	ATC 374	All fabric covered components	
114	Fleet (Brewster)	Fleet (Phillips) 7	TC 2-562	All fabric covered components	
115	Fleet (Brewster)	Fleet 8, 9	ATC 428	All fabric covered components	
116	Fleet (Brewster)	16B (RCAF Finch II)	TC 2-566	All fabric covered components	
117	Fleet (Brewster)	Fleet 80	TC 788	All fabric covered components	
118	Fleetwings (Kaiser)	F-401	TC 2-540	All fabric covered components	1/1/2003
119	Frankfort (Corcoran)	B Glider (Army XTG-1, -TG-1A, -1C)	GTC 7	All fabric covered components	1/1/2003
120	Franklin	Model A (S/N #8)	ATC 2-246	All fabric covered components	1/1/2003
121	Funk (McClish)	B, B75L (Army UC-92), B85C	A-715	All fabric covered components	
122	Great Lakes Aircraft	2T-1	ATC 167	All fabric covered components	

# FAA Approved Model List (AML) No. SA4503NM

Item No.	Aircraft Make	Model	Original Type Certificate	Components	AML Amend.
123	Great Lakes Aircraft (Chapparral)	2T-1A, 2T-1A-1, 2T-1A-2	ATC 228 / A18EA	All fabric covered components	1/1/2003
124	Great Lakes Aircraft	2T-1E	ATC 354	All fabric covered components	
125	Grumman	F7F-3 (Navy Tigercat)	AR-28	All fabric covered components	
126	Grumman	F8F-1 (Navy Bearcat)	LTC-23	All fabric covered components	1/1/2003
127	Grumman	F8F-2 (Navy Bearcat)	AR-32	All fabric covered components	
128	Grumman	FM-2 (Navy Wildcat)	LTC-25	All fabric covered components	
129	Grumman	G21, -21A (Army OA-9, Navy JRF-1, -2, -3, -4, -5, -6B) (Goose)	TC 654	All fabric covered components	
130	Grumman (Gulfstream)	G-44 (Army OA-14, Navy J4F-2), -44A, SCAN Type 30 (Widgeon)	A-734	All fabric covered components	
131	Grumman (Gulfstream)	G-73 (Mallard)	A-783	All fabric covered components	
132	Grumman (Allied Ag Cat)	G-164, G-164A, G-164B	1A16	All fabric covered components	1/1/2003
133	Grumman	Navy TBF & TBM Series (Avenger)	LTC-8	All fabric covered components	
134	Grumman	Navy J2F-3, J2F-4, J2F-5, J2F-6 (Duck)	LTC-17	All fabric covered components	
135	Grumman	HU-16A, HU-16B (Albatross)	A33SO	All fabric covered components	1/1/2003
136	Harlow (Peacock)	PJC-1, -2 (Army UC-80)	TC 659	All fabric covered components	1/1/2003
137	Helio	H-250, H-295 (USAF U-10D), H-391 (USAF YL-24), H-391B, H-395 (USAF L-28A), H-395A	1A8	All fabric covered components	1/1/2003
138	Helton (Spinks)	Lark 95	A-748	All fabric covered components	1/1/2003
139	Hiller Aviation	UH-12B, UH-12C	6H2	All fabric covered components	
<b>140</b>	<b>Hiller Aviation</b>	<b>UH-12D</b>	<b>4H10</b>	<b>All fabric covered components</b>	<b>6/1/2008</b>
141	Howard (Jobmaster)	DGA-11	TC 672	All fabric covered components	
142	Howard (Jobmaster)	DGA-15J (Army UC-70B), DGA-15P (Army UC-70), Navy GH-1, -2, -3, NH-1), DGA-15W	A-717	All fabric covered components	
143	Inland	W-500	ATC 315	All fabric covered components	1/1/2003
144	Interstate (Callair)	S-1A, S-1A-65F, -85F, -90F	A-737	All fabric covered components	
145	Interstate (Callair)	S-1B1 (Army L-6, XL-6)	A-754	All fabric covered components	

## FAA Approved Model List (AML) No. SA4503NM

Item No.	Aircraft Make	Model	Original Type Certificate	Components	AML Amend.
146	Intreprinderea De Constructii Aeronautice Brasov	IS-28B2 Glider	G40EU	All fabric covered components	
147	<b>Johnson (Pirtle)</b>	<b>Johnson Rocket 185</b>	<b>TC 776</b>	<b>All fabric covered components</b>	<b>6/1/2008</b>
148	Kinner Motors, Inc.	Sportster K	ATC 490	All fabric covered components	1/1/2003
149	Laister-Kauffmann	LK-10A (Army TG-4A), LK-10B	G-15	All fabric covered components	1/1/2003
150	<b>LET Aeronautical Works</b>	<b>L33 SOLO Glider</b>	<b>G71EU</b>	<b>All fabric covered components</b>	<b>6/1/2008</b>
151	Lockheed	1649A-98	4A17	All fabric covered components	
152	Luscombe	8, 8A, 8B, 8C, 8D, 8E, 8F, T-8F	A-694	All fabric covered components	
153	Luscombe	Phantom 1	TC 552	All fabric covered components	
154	Martin-Marietta	202, 202A	A-795	All fabric covered components	
155	Martin-Marietta	404	1A7	All fabric covered components	
156	Maule	Bee Dee M-4, M-4, -4C, -4S, -4T; M-4-180C, S, T; M-4-210, C, S, T; M-4-220, C, S, T; M-5-180C, -200, -210C, -210TC, -220C, -235C; M-6-180, -235; M-7-235; MX-7-235, -180	3A23	All fabric covered components	1/1/2003
157	McKinnon	G-21G	4A24	All fabric covered components	
158	Meyers	OTW, -KR, -145, -160	A-736	All fabric covered components	1/1/2003
159	Monocoupe	90, 90A, 90AF, 90AF-100, 90AL-115	A-306	All fabric covered components	
160	Monocoupe	110	TC-327	All fabric covered components	1/1/2003
161	Mooney	M20, M20A, M20B, M20C, M20D, M20E, M20F, M20G	2A3	All fabric covered components	1/1/2003
162	Mooney Mite	M-18C, -18C55, -18L, -18LA	A-803	All fabric covered components	1/1/2003
163	Moth/Hawker	60GM, 60GMW	ATC 197	All fabric covered components	1/1/2003
164	Naval Aircraft Factory	Navy N3N-3	A-2-569	All fabric covered components	
165	Nord-Aviation (Aerospatiale)	Nord 262 A-12	A6EU	All fabric covered components	
166	Noorduyn	Army UC-64, Norseman Mark VI, UC-64A, UC-64B, UC-64AS	A-2-578	All fabric covered components	1/1/2003
167	North American	BC-1A, AT-6 (SNJ-2), -6A (SNJ-3), -6B, -6C (SNJ-4), -6D (SNJ-5), -6F (SNJ-6, -7), T-6G	A-2-575	All fabric covered components	



# FAA Approved Model List (AML) No. SA4503NM

Item No.	Aircraft Make	Model	Original Type Certificate	Components	AML Amend.
168	North American (Shell)	Army RB-25; B-25C, G, H, J; B-25N; TB-25N	LTC-2	All fabric covered components	1/1/2003
169	North American (Cavalier)	Army P-51C, D, K	LTC-11	All fabric covered components	
170	Nelson	BB-1 Glider	GTC 19	All fabric covered components	1/1/2003
171	Pasped	Skylark W-1	TC 2-546	All fabric covered components	1/1/2003
<b>172</b>	<b>Pheasant Aircraft Corp.</b>	<b>Pheasant H-10</b>	<b>ATC 36</b>	<b>All fabric covered components</b>	<b>6/1/2008</b>
173	Piaggio	P.136-L, -L1, -L2	A-813	All fabric covered components	1/1/2003
174	Piper	Cub E-2	ATC 455	All fabric covered components	1/1/2003
175	Piper	J-2	ATC 595	All fabric covered components	1/1/2003
176	Piper	J3C-40, -50, -50S, -65 (Army L-4, L-4A, L-4B (Navy NE-1), L-4H, L-4J (Navy NE-2)), -65S, PA-11, PA-11S	A-691	All fabric covered components	
177	Piper	J3F-50, -50S, -60, -60S, -65 (Army L-4D), -65S	A-692	All fabric covered components	
178	Piper	J3L, -S, -65 (Army L-4C), -65S	A-698	All fabric covered components	
179	Piper	J4, J4A, J4A-S	A-703	All fabric covered components	
180	Piper	J4B	TC 708	All fabric covered components	
181	Piper	J4E (Army L-4E)	A-740	All fabric covered components	
182	Piper	J4F	TC 721	All fabric covered components	
183	Piper	J5A (Army L-4F), J5A-80, J5B (Army L-4G), J5C, AE-1, HE-1	A-725	All fabric covered components	
184	Piper	PA-12, PA-12S	A-780	All fabric covered components	
185	Piper	PA-14	A-797	All fabric covered components	
186	Piper	PA-15	A-800	All fabric covered components	
187	Piper	PA-16, PA-16S	1A1	All fabric covered components	
188	Piper	PA-17	A-805	All fabric covered components	
189	Piper	PA-18, PA-18S, PA-18 "105" (Special), PA-18S "105" (Special), PA-18A, PA-18 "125" (Army L-21A), PA-18S "125", PA-18AS "125", PA-18 "135" (Army L-21B), PA-18A "135", PA-18S "135", PA-18AS "135", PA-18 "150", PA-18A "150", PA-18S "150", PA-18AS "150", PA-19 (Army L-18C), PA-19S	1A2	All fabric covered components	1/1/2003

# FAA Approved Model List (AML) No. SA4503NM

Item No.	Aircraft Make	Model	Original Type Certificate	Components	AML Amend.
190	Piper	Restricted Category PA-18A, PA-18A-135, PA-18A-150	AR-7	All fabric covered components	
191	Piper	PA-20, PA-20S, PA-20 "115", PA-20S "115", PA-20 "135", PA-20S "135"	1A4	All fabric covered components	
192	Piper	PA-22, -22-108, -22-135, -22S-135, -22-150, -22S-150, -22-160, -22S-160	1A6	All fabric covered components	
193	Piper	PA-25, -25-235, -25-260	2A8 / 2A10	All fabric covered components	1/1/2003
194	Pitcairn Autogyro	PA-5	ATC 18	All fabric covered components	1/1/2003
<b>195</b>	<b>Pitcairn Autogyro</b>	<b>PA-18</b>	<b>ATC 478</b>	<b>All fabric covered components</b>	<b>6/1/2008</b>
196	Pitts	S-1S, S-1T, S-2, S-2A, S-2S, S-2B	A8SO	All fabric covered components	1/1/2003
197	Porterfield	CP-50	TC 690	All fabric covered components	1/1/2003
198	Porterfield (Rankin)	CP-55, -65, CS-65, FP-65, LP-65	A-720	All fabric covered components	1/1/2003
199	Porterfield (Rankin)	35, 35-70	ATC 567	All fabric covered components	
200	Pratt, Reed (Gould)	PR-G1 (Army TG-32, Navy LNE-1) Glider	GTC 12	All fabric covered components	1/1/2003
201	PZL-Krosno	KR-03A Puchatek	G56EU	All fabric covered components	1/1/2003
202	Rearwin (Commonwealth)	175, 180, 180F, 185, 190F	A-729	All fabric covered components	
203	Commonwealth (Pigman/Reed)	Rearwin 6000M	TC 661	All fabric covered components	
204	Commonwealth	Rearwin 7000	TC 574	All fabric covered components	1/1/2003
205	Rearwin (Pigman)	Rearwin 8090, 8125, 8135 (Army UC-102A), 8135T	TC 711	All fabric covered components	1/1/2003
206	Commonwealth (Pigman/Reed)	Rearwin 9000, 9000 Deluxe	TC 624	All fabric covered components	
<b>207</b>	<b>Roos Aircraft Co.</b>	<b>Roos-Lincoln PT-W</b>	<b>ATC 284</b>	<b>All fabric covered components</b>	<b>6/1/2008</b>
208	Rose Aeroplane and Motor Company	Parakeet A-1	TC 2-514	All fabric covered components	1/1/2003
209	Ryan Aeronautical	ST-3KR (Army PT-22, -22A)	A-749	All fabric covered components	
210	Ryan Aeronautical	ST-A	ATC 571	All fabric covered components	1/1/2003
211	Ryan Aeronautical	SCW-145	TC 658	All fabric covered components	
212	Scheibe-Flugzeugbau	Bergfalke II/55, III Gliders	7G9	All fabric covered components	1/1/2003

# FAA Approved Model List (AML) No. SA4503NM

Item No.	Aircraft Make	Model	Original Type Certificate	Components	AML Amend.
213	Scheibe-Flugzeugbau	Zugvogel IIIB Glider	G4EU	All fabric covered components	1/1/2003
214	Schempp-Hirth	SHK1 Glider	G9EU	All fabric covered components	1/1/2003
215	Schempp-Hirth	Standard Austria-S Glider	G1IN	All fabric covered components	
216	Schleicher	Ka 6, Ka 6B, Ka 6C, Ka 6CR, Ka 6CR-Pe, KA 6E Gliders	7G1	All fabric covered components	1/1/2003
217	Schleicher	K7, Ka2b Gliders	7G3	All fabric covered components	1/1/2003
218	Schleicher	K8, K8B Gliders	7G4	All fabric covered components	1/1/2003
219	Schleicher	AS-K13 Glider	G15EU	All fabric covered components	1/1/2003
220	Schweizer	SGU-1-19, -19A Gliders	G-17	All fabric covered components	1/1/2003
221	Schweizer	SGU 2-22, -22A, -22B, -22C, -22CK, -22E, -22EK Gliders	G-18	All fabric covered components	
222	Schweizer	SGS 1-26, -26A, -26B, -26C, -26D, -26E Gliders	1G10	All fabric covered components	1/1/2003
223	Schweizer	SGS 2-8, SGS 2-8A Gliders	GTC 5	All fabric covered components	1/1/2003
224	Schweizer	SGS 2-32 Glider	G1EA	All fabric covered components	1/1/2003
225	Schweizer	SGS 2-33, -33A, -33AK Gliders	G2EA	All fabric covered components	1/1/2003
226	Schweizer	SGS1-34, -34R Gliders	G3EA	All fabric covered components	1/1/2003
227	Schweizer	TG-3A Army Glider	TC G-2-11	All fabric covered components	
228	Sikorsky	VS-44-A	TC 752	All fabric covered components	
229	Spartan	7W (Army UC-71)	TC 628	All fabric covered components	
230	Stearman	C-3-B	ATC 55	All fabric covered components	1/1/2003
231	Stearman-Hammond	Y1S	TC 644	All fabric covered components	1/1/2003
232	Stearman-Boeing	A75L3, 75 (Army PT-13), A75 (Army PT-13A, -13B, -13C), B75 (Navy N2S-2), E75 (Army PT-13D; Navy N2S-5; PT-13D/N2S-5), A75J1 (Army PT-18), A75L300, A75N1 (Army PT-17, -17A; Navy N2S-1, -4), B75N1 (Navy N2S-3), D75N1 (Army PT-27), IB75A, E75N1	A-743	All fabric covered components	
233	Stearman-Boeing	4-C	TC 2-155	All fabric covered components	
234	Stearman	4E	ATC 292	All fabric covered components	1/1/2003
235	<b>Stinson</b>	<b>SM-2AA</b>	<b>ATC 145</b>	<b>All fabric covered components</b>	<b>6/1/2008</b>

# FAA Approved Model List (AML) No. SA4503NM

Item No.	Aircraft Make	Model	Original Type Certificate	Components	AML Amend.
236	Stinson	SM-8A	ATC 295	All fabric covered components	
237	Stinson	SM-8B, -8BT	ATC 294	All fabric covered components	1/1/2003
238	Stinson	SR-5, -5A (Army L-12), -5B, -5C, -5E	ATC 530	All fabric covered components	1/1/2003
239	Stinson	SR-7A, -7B, -7C	ATC 594	All fabric covered components	
240	Stinson	SR-8A, SR-8B (Army UC-81), SR-8C (Army UC-81L)	ATC 608	All fabric covered components	
241	Stinson	SR-8D (Army UC-81B), SR-8E	ATC 609	All fabric covered components	
242	Stinson	SR-9A, SR-9B (Army UC-81N), SR-9C (Army UC-81C)	ATC 621	All fabric covered components	
243	Stinson	SR-9D (Army UC-81G), SR-9DM, SR-9E (Army UC-81J), SR-9EM (Army UC-81M)	ATC 625	All fabric covered components	
244	Stinson	SR-9F (Army UC-81E)	ATC 640	All fabric covered components	
245	Stinson	HW-75, 10	A-709	All fabric covered components	
246	Stinson	10A (Army L-9B), 10B	A-738	All fabric covered components	
247	Stinson	Army L-1	LTC-26	All fabric covered components	
248	Stinson	L-5, -5B, -5C, -5D, -5E, -5E-1, -5G	A-764	All fabric covered components	
249	Stinson	108, 108-1, -2, -3, -5	A-767	All fabric covered components	1/1/2003
250	Stinson	V-77 (Army AT-19)	A-774	All fabric covered components	
251	Taylorcraft	Model A	A-643	All fabric covered components	1/1/2003
252	Taylorcraft	DC-65 (Army L-2, -2C), DCO-65 (Army L-2A, -2B, -2M), DF-65 (Army L-2E), DL-65 (Army L-2D)	A-746	All fabric covered components	1/1/2003
253	Taylorcraft	BC, BCS, BC-65, BCS-65, BC12-65 (Army L-2H), BCS12-65, BC12-D, BCS12-D, BC12-D1, BCS12-D1, BC12D-85, BCS12D-85, BC12D-4-85, BCS12D-4-85	A-696	All fabric covered components	1/1/2003
254	Taylorcraft	BF (Army L-2G), BFS, BF-60, BFS-60, BF-65, BFS-65, BF12-65 (Army L-2K), BFS12-65	A-699	All fabric covered components	
255	Taylorcraft	BL, BLS, BL-65 (Army L-2F), BLS-65, BL12-65 (Army L-2J), BLS12-65	A-700	All fabric covered components	
256	Taylorcraft	19, F19, F21, F21A, F21B, F22, F22A	1A9	All fabric covered components	1/1/2003
257	Taylorcraft (Helio)	Model 15A, 20	3A3	All fabric covered components	

## FAA Approved Model List (AML) No. SA4503NM

Item No.	Aircraft Make	Model	Original Type Certificate	Components	AML Amend.
258	Travel Air (Curtiss-Wright)	Travel Air 12-W	ATC 407	All fabric covered components	
259	<b>Travel Air (Curtiss-Wright)</b>	<b>Travel Air 3000</b>	<b>ATC 31</b>	<b>All fabric covered components</b>	<b>6/1/2008</b>
260	Travel Air (Curtiss-Wright)	Travel Air 4000	ATC 32	All fabric covered components	
261	Travel Air (Curtiss-Wright)	Travel Air B-4000	ATC 146	All fabric covered components	
262	Travel Air (Curtiss-Wright)	Travel Air B9-4000	TC 2-381	All fabric covered components	
263	Travel Air (Curtiss-Wright)	Travel Air C-4000	ATC 149	All fabric covered components	
264	Travel Air (Curtiss-Wright)	Travel Air D-4D	TC 2-178	All fabric covered components	
265	Travel Air (Curtiss-Wright)	Travel Air D-4000	TC 2-84	All fabric covered components	
266	Travel Air (Curtiss-Wright)	Travel Air E-4000	ATC 188	All fabric covered components	
267	Travel Air (Curtiss-Wright)	Travel Air K-4000	ATC 205	All fabric covered components	
268	Travel Air (Curtiss-Wright/Parks)	Travel Air L-4000	TC 2-560	All fabric covered components	
269	Travel Air (Curtiss-Wright)	Travel Air W-4000	ATC 112	All fabric covered components	
270	Waco	ASO	ATC 41	All fabric covered components	1/1/2003
271	Waco	AVN-8	TC 677	All fabric covered components	
272	Waco	CSO	ATC 240	All fabric covered components	1/1/2003
273	Waco	CTO	ATC 257	All fabric covered components	1/1/2003
274	Waco	CUC-1, CUC-2	ATC 575	All fabric covered components	1/1/2003
275	Waco	GXE	ATC 13	All fabric covered components	1/1/2003
276	<b>Waco</b>	<b>INF</b>	<b>ATC 345</b>	<b>All fabric covered components</b>	<b>6/1/2008</b>
277	Waco	QCF	ATC 416	All fabric covered components	1/1/2003
278	Waco	RNF	ATC 311	All fabric covered components	
279	Waco	UBF	ATC 473	All fabric covered components	

## FAA Approved Model List (AML) No. SA4503NM

Item No.	Aircraft Make	Model	Original Type Certificate	Components	AML Amend.
280	Waco	UEC	ATC 467	All fabric covered components	
281	Waco	UIC	ATC 499	All fabric covered components	
<b>282</b>	<b>Waco</b>	<b>UKS-7</b>	<b>ATC 648</b>	<b>All fabric covered components</b>	<b>6/1/2008</b>
283	Waco	UPF-7, VPF-7	A-642	All fabric covered components	
284	Waco	YKS-7 (Army UC-72K), ZKS-7 (Army UC-72M)	TC 626	All fabric covered components	
<b>285</b>	<b>Waco</b>	<b>YMF-5</b>	<b>ATC 542</b>	<b>All fabric covered components</b>	<b>6/1/2008</b>
<b>286</b>	<b>Waco</b>	<b>YPF</b>	<b>ATC 586</b>	<b>All fabric covered components</b>	<b>6/1/2008</b>
<b>287</b>	<b>Waco</b>	<b>ZKS-6</b>	<b>A-533</b>	<b>All fabric covered components</b>	<b>6/1/2008</b>
288	White Aircraft Corp.	New Standard D25	ATC 108	All fabric covered components	1/1/2003

Note: When a design is changed to metal skin and manufactured under the same TC number (e.g., the Luscombe Model 8, all models optional fabric or metal covered wing), our STC is applicable only to those models with fabric covered components. Check the aircraft nameplate for the TC number or check with the local FAA FSDO.

# STAR GLOSS COVERING MATERIAL ESTIMATES

Aircraft and Components	Linear yards of 72-inch C-101/102 fabric; Light for plywood surfaces is listed separately.	Star-Tak Fabric Cement	One Coat Plus Taping		Polyester Finishing Tape Rolls ("B" = Bias)	Rib Lacing Cord (See Note 1)	Reinforcing Tape (Width same as cap strip)	Two Cross Coats			Two Coats			
			Gray Sealer, Gal (Thin 3:1)	Gray Sealer Reducer, Gal				Silver Urethane Fabric Primer, Gal (Thin 3:1)	Silver Urethane Fabric Primer Catalyst, Qt (4:1)	Randolph G-4200 Thinner, Gal	Randolph Ranthane HS Polyurethane Finish, Gal (Thin 3:1) (See Note 2)	Randolph Ranthane Catalyst AU-CAT-2X1, Qt (2:1)	Randolph G-4200 Ranthane Thinner, Gal	

**NOTE 1:** Delete rib lacing thread for those model aircraft that use wire clips or screws instead of rib lacing.

**NOTE 2:** Quantity estimates of RANTHANE finish are based on fabric covered areas. Add appropriate additional amount for large metal portions of aircraft.

**NOTE 3:** Add 1 spool polyester machine sewing thread if envelopes or a blanket are to be sewn.

**NOTE 4:** "Wet goods" are sold in gallons, quarts, pints, and half pints.

**Light aircraft size & configuration of: AERONCA CHAMPION, AERONCA CHIEF, CALLAIR, CITABRIA, FUNK, INTERSTATE CADET, PIPER J-3, -4, -5, PA-11, -12, -14, -18, -25, PORTERFIELD, REARWIN, TAYLORCRAFT, etc.**

Complete Aircraft	45 yd	1 Gal	5 Gal	2 Gal	1(1"), 7(2"), 2(3"), 1(4"), 1(3"B), 1(4"B)	1	2(1/2")	4 Gal	4 Qt	2 Gal	4 Gal	8 Qt	2 Gal	2 Gal
2 Wings & Ailerons	25 yd	2 Qt	2 3/4 Gal	1 1/4 Gal	4(2"), 2(3"), 1(4"), 1(4"B)	1	2(1/2")	2 1/4 Gal	2 1/4 Qt	1 1/4 Gal	2 1/4 Gal	4 1/2 Qt	1 1/4 Gal	1 1/4 Gal
Fuselage	11 yd	1 Qt	1 1/4 Gal	2 Qt	1(1"), 2(2")			1 Gal	1 Qt	2 Qt	1 Gal	2 Qt	2 Qt	2 Qt
5 Tail Surfaces	9 yd	1 Qt	1 Gal	2 Qt	2(2"), 1(3"B)	50'	1(1/2")	1 Gal	1 Qt	2 Qt	1 Gal	2 Qt	2 Qt	2 Qt
Complete Less Fuselage	34 yd	3 Qt	3 3/4 Gal	1 1/2 Gal	5(2"), 2(3"), 1(4"), 1(3"B), 1(4"B)	1	2(1/2")	3 Gal	3 Qt	1 1/2 Gal	3 Gal	6 Qt	1 1/2 Gal	1 1/2 Gal
Complete Less 2 Wings	20 yd	2 Qt	2 1/4 Gal	1 Gal	1(1"), 3(2"), 1(3"B)	50'	1(1/2")	1 3/4 Gal	1 3/4 Qt	1 Gal	1 3/4 Gal	3 1/2 Qt	1 Gal	1 Gal
All Control Surfaces	11 yd	1 Qt	1 1/4 Gal	2 Qt	2(2"), 1(3"), 1(3"B)	50'	1(1/2")	1 Gal	1 Qt	2 Qt	1 Gal	2 Qt	2 Qt	2 Qt

**Light aircraft size & configuration of: PIPER PA-15, 16, 17, 20, 22, etc.**

Complete Aircraft	40 yd	1 Gal	4 1/2 Gal	1 3/4 Gal	1(1"), 6(2"), 2(3"), 1(4"), 1(3"B), 1(4"B)	1	1(1/2")	3 1/2 Gal	3 1/2 Qt	1 3/4 Gal	3 1/2 Gal	7 Qt	1 3/4 Gal	1 3/4 Gal
Fuselage	11 yd	1 Qt	1 1/4 Gal	2 Qt	1(1"), 2(2")			1 Gal	1 Qt	2 Qt	1 Gal	2 Qt	2 Qt	2 Qt
2 Wings & Ailerons	24 yd	2 Qt	2 3/4 Gal	1 Gal	4(2"), 2(3"), 1(4"), 1(4"B)	1	1(1/2")	2 1/4 Gal	2 1/4 Qt	1 1/4 Gal	2 1/4 Gal	4 1/2 Qt	1 1/4 Gal	1 1/4 Gal
5 Tail Surfaces	9 yd	1 Qt	1 Gal	2 Qt	2(2"), 1(3"B)	50'	1(1/2")	1 Gal	1 Qt	2 Qt	1 Gal	2 Qt	2 Qt	2 Qt
Complete Less Fuselage	29 yd	3 Qt	3 1/4 Gal	1 1/4 Gal	5(2"), 2(3"), 1(4"), 1(3"B), 1(4"B)	1	1(1/2")	2 1/2 Gal	2 1/2 Qt	1 1/4 Gal	2 1/2 Gal	5 Qt	1 1/4 Gal	1 1/4 Gal
Complete Less 2 Wings	28 yd	1 Gal	3 1/4 Gal	1 1/4 Gal	1(1"), 3(2"), 1(3"B)	50'	1(1/2")	2 1/2 Gal	2 1/2 Qt	1 1/4 Gal	2 1/2 Gal	5 Qt	1 1/4 Gal	1 1/4 Gal

# STAR GLOSS COVERING MATERIAL ESTIMATES

Aircraft and Components	Linear yards of 72-inch C-101/102 fabric; Light for plywood surfaces is listed separately.	Star-Tak Fabric Cement	One Coat Plus Taping		Polyester Finishing Tape Rolls ("B" = Bias)	Rib Lacing Cord (See Note 1)	Reinforcing Tape (Width same as cap strip)	Two Cross Coats			Two Coats		
			Gray Sealer, Gal (Thin 3:1)	Gray Sealer Reducer, Gal				Silver Urethane Fabric Primer, Gal (Thin 3:1)	Silver Urethane Fabric Primer Catalyst, Qt (4:1)	Randolph G-4200 Thinner, Gal	Randolph Ranthane HS Polyurethane Finish, Gal (Thin 3:1) (See Note 2)	Randolph Ranthane Catalyst AU-CAT-2X1, Qt (2:1)	Randolph G-4200 Ranthane Thinner, Gal
<b>AERONCA 15AC Fuselage &amp; Tail</b>	30 yd	2 Qt	3 1/4 Gal	1 1/4 Gal	1(1"), 2(2"), 1(3"), 1(4"B)		1(3/8")	2 1/2 Gal	2 1/2 Qt	1 1/2 Gal	2 1/2 Gal	5 Qt	1 1/4 Gal
<b>BEECH STAGGERWING D-17 &amp; WACO CABIN</b>	70 yd	1 Gal 2 Qt	7 3/4 Gal	3 1/4 Gal	2(1"), 14(2"), 2(3"), 1(4"), 1(3"B), 1(4"B)	2	6(3/8")	6 1/4 Gal	6 1/4 Qt	3 1/4 Gal	6 1/4 Gal	12 1/2 Qt	3 1/4 Gal
<b>BELLANCA MODEL 14</b>													
Complete Aircraft	21 yd 33 yd Lt	3 Qt	6 Gal	2 1/2 Gal	5(2"), 1(3")	1	1(3/8")	5 Gal	5 Qt	2 1/2 Gal	5 Gal	10 Qt	2 1/2 Gal
Control Surfaces	7 yd	1 Qt	3 Qt	2 Qt	2(2"), 1(3")	50'	1(3/8")	3 Qt	1 1/2 HP	2 Qt	3 Qt	3 Pt	2 Qt
<b>BUCHER JUNGMIESTER</b>	40 yd	3 Qt	4 1/2 Gal	1 3/4 Gal	2(1"), 7(2"), 1(3")	1	1(3/8")	3 1/2 Gal	3 1/2 Qt	1 3/4 Gal	3 1/2 Gal	7 Qt	1 3/4 Gal
<b>CESSNA 120/140/170 Wings</b>	25 yd	1 Qt	2 3/4 Gal	1 1/4 Gal	4(2"), 1(3"), 1(4"), 1(4"B)		1(1/2")	2 1/4 Gal	2 1/4 Qt	1 1/4 Gal	2 1/4 Gal	4 1/2 Qt	1 1/4 Gal
<b>CESSNA UC-78 (T-50)</b>	140 yd	2 Gal	15 1/2 Gal	6 1/4 Gal	2(1"), 30(2"), 3(3"), 1(4"), 1(3"B), 1(4"B)	3	7(3/8")	12 1/2 Gal	12 1/2 Qt	6 1/4 Gal	12 1/2 Gal	25 Qt	6 1/4 Gal
<b>CONSOLIDATED VULTEE BT-13 Control Surfaces</b>	12 yd	1 Qt	1 1/2 Gal	2 Qt	2(2"), 1(3")		1(1/2")	1 Gal	1 Qt	2 Qt	1 Gal	2 Qt	2 Qt
<b>CULVER CADET</b>	23 yd	2 Qt	2 1/2 Gal	1 Gal	4(2"), 1(3"), 1(4"), 1(4"B)	1	1(1/2")	2 Gal	2 Qt	1 Gal	2 Gal	4 Qt	1 Gal
<b>DOUGLAS DC-3</b>	30 yd	1 Gal	3 1/4 Gal	1 1/4 Gal	6(2"), 2(3"), 1(3"B)	1	1(1/2")	2 1/2 Gal	2 1/2 Qt	1 1/2 Gal	2 1/2 Gal	5 Qt	1 1/4 Gal
<b>DeHAVILLAND CHIPMUNK DH-C1</b>	30 yd	2 Qt	3 1/4 Gal	1 1/4 Gal	4(2"), 1(3"), 1(4")		1(1/2")	2 1/2 Gal	2 1/2 Qt	1 1/2 Gal	2 1/2 Gal	5 Qt	1 1/4 Gal
<b>ERCOUPE Both Wings</b>	17 yd	1 Qt	2 Gal	3 Qt	2(2"), 1(3"), 1(4"), 1(4"B)		1(1/2")	1 1/2 Gal	1 1/2 Qt	3 Qt	1 1/2 Gal	3 Qt	3 Qt
<b>FAIRCHILD 24</b>	47 yd 8 yd Lt	3 Qt	6 1/4 Gal	2 1/2 Gal	1(1"), 8(2"), 2(3"), 1(4"), 1(4"B)	1	2(3/8")	5 Gal	5 Qt	2 1/2 Gal	5 Gal	10 Qt	2 1/2 Gal
<b>FAIRCHILD PT-19, 23, 26</b>	32 yd 33 yd Lt	1 Gal	7 1/4 Gal	3 Gal	1(1"), 2(2"), 1(3")	50'	1(1/2")	5 3/4 Gal	5 3/4 Qt	3 Gal	5 3/4 Gal	11 1/2 Qt	3 Gal



# STAR GLOSS COVERING MATERIAL ESTIMATES

Aircraft and Components	Linear yards of 72-inch C-101/102 fabric; Light for plywood surfaces is listed separately.	Star-Tak Fabric Cement	One Coat Plus Taping		Polyester Finishing Tape Rolls ("B" = Bias)	Rib Lacing Cord (See Note 1)	Reinforcing Tape (Width same as cap strip)	Two Cross Coats				Two Coats			
			Gray Sealer, Gal (Thin 3:1)	Gray Sealer Reducer, Gal				Silver Urethane Fabric Primer, Gal (Thin 3:1)	Silver Urethane Fabric Primer Catalyst, Qt (4:1)	Randolph G-4200 Thinner, Gal	Randolph Ranthane HS Polyurethane Finish, Gal (Thin 3:1) (See Note 2)	Randolph Ranthane Catalyst AU-CAT-2X1, Qt (2:1)	Randolph G-4200 Ranthane Thinner, Gal		
<b>FLEET, FRENCH STAMPE, GREAT LAKES, PJ-260, TRAVEL AIR 12 &amp; 16E, etc.</b>															
Complete Aircraft	60 yd	1 Gal	6 3/4 Gal	2 3/4 Gal	1(1"), 10(2"), 2(3"), 1(4"), 1(4"B)	1	4(3/8")	5 1/2 Gal	5 1/2 Qt	2 3/4 Gal	5 1/2 Gal	11 Qt	2 3/4 Gal	Randolph Ranthane Catalyst AU-CAT-2X1, Qt (2:1)	Randolph G-4200 Ranthane Thinner, Gal
4 Wings	36 yd	2 Qt	4 Gal	1 1/2 Gal	10(2"), 2(3"), 1(4"), 1(4"B)	1	4(3/8")	3 1/4 Gal	3 1/4 Qt	1 1/2 Gal	3 1/4 Gal	6 1/2 Qt	1 1/2 Gal		
<b>GRUMMAN AG-CAT</b>	24 yd	2 Qt	2 3/4 Gal	1 Gal	4(2"), 1(3"), 1(4")		1(3/8")	2 1/4 Gal	2 1/4 Qt	1 1/4 Gal	2 1/4 Gal	4 1/2 Qt	1 1/4 Gal		
<b>HOWARD DGA 15</b>	25 yd 33 yd Lt	1 Gal	6 1/2 Gal	2 1/2 Gal	1(1"), 10(2"), 2(3"), 1(4"), 1(4"B)	1	2(1/4")	5 1/4 Gal	5 1/4 Qt	2 1/2 Gal	5 1/4 Gal	10 1/2 Qt	2 1/2 Gal		
<b>LUSCOMBE MODEL 8</b>	22 yd	1 Qt	2 1/2 Gal	1 Gal	4(2"), 1(3"), 1(4")	1	1(1/2")	2 Gal	2 Qt	1 Gal	2 Gal	4 Qt	1 Gal		
<b>MAULE</b>	28 yd	1 Gal	3 1/4 Gal	1 1/4 Gal	1(1"), 5(2"), 1(3"), 1(4")	1	1(1/2")	2 1/2 Gal	2 1/2 Qt	1 1/4 Gal	2 1/2 Gal	5 Qt	1 1/4 Gal		
<b>MOONEY MITE M-18</b>	12 yd 20 yd Lt	2 Qt	3 1/2 Gal	1 1/2 Gal	1(1"), 2(2"), 1(3")	1	1(3/8")	2 3/4 Gal	2 3/4 Qt	1 1/2 Gal	3 Gal	6 Qt	1 1/2 Gal		
<b>NORTH AMERICAN BC-1A, AT-6, -6A, -6B, -6C, -6D, -6F, -6G, T-6G</b>															
Rudder, 2 Elevators, Ailerons	9 yd	1 Qt	1 Gal	2 Qt	2(2"), 2(3"), 1(4")		1(1/2")	1 Gal	1 Qt	2 Qt	1 Gal	2 Qt	2 Qt		
2 Ailerons	3 yd	1 Qt	2 Qt	1 Qt	1(2"), 1(3")		1(1/2")	1 Qt	1 HP	1 Qt	1 Qt	1 Pint	1 Qt		
Rudder, 2 Ailerons	6 1/2 yd	1 Qt	3 Qt	2 Qt	2(2"), 1(3")		1(1/2")	3 Qt	HP	2 Qt	3 Qt	3 Pint	2 Qt		
<b>RYAN PT-22 &amp; RYAN ST</b>	29 yd	2 Qt	3 1/4 Gal	1 1/4 Gal	3(2"), 1(3"), 1(4"), 1(4"B)	1	1(1/2")	2 1/2 Gal	2 1/2 Qt	1 1/4 Gal	2 1/2 Gal	5 Qt	1 1/4 Gal		
<b>RYAN BROUGHAM</b>	78 yd	1 Gal	8 3/4 Gal	3 1/2 Gal	1(1"), 11(2"), 2(3"), 1(4"), 1(4"B)	1	3(1/2")	7 Gal	7 Qt	3 1/2 Gal	7 Gal	14 Qt	3 1/2 Gal		

# STAR GLOSS COVERING MATERIAL ESTIMATES

Aircraft and Components	Linear yards of 72-inch C-101/102 fabric; Light for plywood surfaces is listed separately.	Star-Tak Fabric Cement	One Coat Plus Taping		Polyester Finishing Tape Rolls ("B" = Bias)	Rib Lacing Cord (See Note 1)	Reinforcing Tape (Width same as cap strip)	Two Cross Coats			Two Coats		
			Gray Sealer, Gal (Thin 3:1)	Gray Sealer Reducer, Gal				Silver Urethane Fabric Primer, Gal (Thin 3:1)	Silver Urethane Fabric Primer Catalyst, Qt (4:1)	Randolph G-4200 Thinner, Gal	Silver Urethane Fabric Primer, Gal (Thin 3:1)	Randolph Ranthane HS Polyurethane Finish, Gal (Thin 3:1) (See Note 2)	Randolph Ranthane Catalyst AU-CAT-2X1, Qt (2:1)
<b>STEARMAN-BOEING PT-13, -17, -18, -27, N2S-3, NAVY N3N, TRAVEL AIR 4000, WACO UPF-7, etc.</b>													
Complete Aircraft	65 yd	1 Gal	7 1/4 Gal	3 Gal	1(1"), 1(2"), 2(3"), 2(4"), 1(4"B)	1	4(3/8")	5 3/4 Gal	3 Gal	3 Gal	5 3/4 Gal	11 1/2 Qt	3 Gal
4 Wing Panels	40 yd	3 Qt	4 1/2 Gal	1 3/4 Gal	11(2"), 2(3"), 2(4"), 1(4"B)	1	3(3/8")	3 1/2 Gal	3 1/2 Qt	1 3/4 Gal	3 1/2 Gal	7 Qt	1 3/4 Gal
Fuselage	12 yd	1 Qt	1 1/2 Gal	2 Qt	1(1"), 2(2")			1 Gal	1 Qt	2 Qt	1 Gal	2 Qt	2 Qt
6 Tail Surfaces	13 yd	2 Qt	1 1/2 Gal	2 Qt	3(2"), 1(3"), 1(4"B)	50'	1(3/8")	1 1/4 Gal	1 1/4 Qt	2 Qt	1 1/4 Gal	2 1/2 Qt	2 Qt
<b>STINSON 10, 10A, 10B, HW-75</b>	42 yd 5 yd Lt	2 Qt	5 1/4 Gal	2 Gal	1(1"), 6(2"), 1(3"), 1(4"), 1(4"B)		1(1/2")	4 1/4 Gal	4 1/4 Qt	2 Gal	4 1/4 Gal	8 1/2 Qt	2 Gal
<b>STINSON 108</b>													
Complete Aircraft	40 yd	2 Qt	4 1/2 Gal	1 3/4 Gal	1(1"), 6(2"), 1(3"), 1(4")		1(1/2")	3 1/2 Gal	3 1/2 Qt	1 3/4 Gal	3 1/2 Gal	7 Qt	1 3/4 Gal
Fuselage	14 yd	2 Qt	1 1/2 Gal	3 Qt	1(1"), 2(2")			1 1/4 Gal	1 1/4 Qt	3 Qt	1 1/4 Gal	2 1/2 Qt	3 Qt
2 Wings & Ailerons	25 yd	1 Qt	2 3/4 Gal	1 1/4 Gal	5(2"), 1(3"), 1(4")		1(1/2"), 1(3/8")	2 1/4 Gal	2 1/4 Qt	1 1/4 Gal	2 1/4 Gal	4 1/2 Qt	1 1/4 Gal
<b>STINSON AT-19 &amp; V-77</b>													
Complete Aircraft	78 yd	1 Gal	8 3/4 Gal	3 1/2 Gal	1(1"), 11(2"), 2(3"), 1(4"), 1(4"B)	2	4(3/8")	7 Gal	7 Qt	3 1/2 Gal	7 Gal	14 Qt	3 1/2 Gal
2 Wings	41 yd	1 Gal	4 1/2 Gal	2 Gal	6(2"), 2(3"), 1(4"), 1(4"B)	2	4(3/8")	3 3/4 Gal	3 3/4 Qt	2 Gal	3 3/4 Gal	7 1/2 Qt	2 Gal
<b>STINSON L-5</b>	45 yd 5 yd Lt	2 Qt	5 1/2 Gal	2 1/4 Gal	6(2"), 1(3"), 1(4")		1(1/2")	4 1/2 Gal	4 1/2 Qt	2 1/4 Gal	4 1/2 Gal	9 Qt	2 1/4 Gal

# STAR GLOSS COVERING MATERIAL ESTIMATES

Aircraft and Components	Linear yards of 72-inch C-101/102 fabric; Light for plywood surfaces is listed separately.	Star-Tak Fabric Cement	One Coat Plus Taping		Polyester Finishing Tape Rolls ("B" = Bias)	Rib Lacing Cord (See Note 1)	Reinforcing Tape (Width same as cap strip)	Two Cross Coats			Two Coats		
			Gray Sealer, Gal (Thin 3:1)	Gray Sealer Reducer, Gal				Silver Urethane Fabric Primer, Gal (Thin 3:1)	Silver Urethane Fabric Primer Catalyst, Qt (4:1)	Randolph G-4200 Thinner, Gal	Randolph Ranthane HS Polyurethane Finish, Gal (Thin 3:1) (See Note 2)	Randolph Ranthane Catalyst AU-CAT-2X1, Qt (2:1)	Randolph G-4200 Ranthane Thinner, Gal
<b>HOMEBUILT/SPORT AIRCRAFT</b>													
Aircraft size & configuration of: BOWER'S FLY-BABY, BOWER'S NAMU II, CORBEN BABY ACE, PIETENPOL, STOLP STARLET													
Complete Aircraft	32 yd	2 Qt	3 1/2 Gal	1 1/2 Gal	1(1"), 5(2"), 1(3")	1	1(3/8")	2 3/4 Gal	2 3/4 Qt	1 1/2 Gal	3 Gal	6 Qt	1 1/2 Gal
2 Wings 26' Span x 4 1/2' Chord	22 yd	1 Qt	2 1/2 Gal	1 Gal	3(2"), 1(3")	1	1(3/8")	2 Gal	2 Qt	1 Gal	2 Gal	4 Qt	1 Gal
AVID FLYER, KITFOX	38 yd	2 Qt	4 1/4 Gal	1 3/4 Gal	5(2"), 1(3"), 1(4"), 1(4"B)	1	2(1/2")	3 1/2 Gal	3 1/2 Qt	1 3/4 Gal	3 1/2 Gal	7 Qt	1 3/4 Gal
BABY GREAT LAKES, MONG, PITTS S-1C, SMITH MINI-PLANE, SUNDAY KNIGHT TWISTER													
Complete Aircraft	25 yd	3 Qt	2 3/4 Gal	1 1/4 Gal	1(1"), 5(2"), 1(3"), 1(4")	1	1(3/8")	2 1/4 Gal	2 1/4 Qt	1 1/4 Gal	2 1/4 Gal	4 1/2 Qt	1 1/4 Gal
4 Wing Panels	20 yd	2 Qt	2 1/4 Gal	1 Gal	5(2"), 1(3"), 1(4")	1	1(3/8")	1 3/4 Gal	1 3/4 Qt	1 Gal	1 3/4 Gal	3 1/2 Qt	1 Gal
CHALLENGER	38 yd	1 Gal	4 1/4 Gal	1 3/4 Gal	6(2"), 2(3"), 1(4")			3 1/2 Gal	3 1/2 Qt	1 3/4 Gal	3 1/2 Gal	7 Qt	1 3/4 Gal
EAA ACRO-SPORT, EAA BI-PLANE, STOLP STARDUSTER 100, etc.													
Complete Aircraft	45 yd	3 Qt	5 Gal	2 Gal	1(1"), 6(2"), 1(3"), 1(4"), 1(4"B)	1	1(3/8")	4 Gal	4 Qt	2 Gal	4 Gal	8 Qt	2 Gal
HATZ, MARQUART CHARGER, STARDUSTER II, STEEN SKY BOLT, etc.													
Complete Aircraft	50 yd	3 Qt	5 1/2 Gal	2 1/4 Gal	2(1"), 8(2"), 1(3"), 1(4"), 1(4"B)	1	1(3/8")	4 1/2 Gal	4 1/2 Qt	2 1/4 Gal	4 1/2 Gal	9 Qt	2 1/4 Gal
PIEL EMERALUDE	33 yd	3 Qt	3 3/4 Gal	1 1/2 Gal	6(2"), 2(3")	1	1(3/8")	3 Gal	3 Qt	1 1/2 Gal	3 Gal	6 Qt	1 1/2 Gal
SONERAI I Fuselage and Tail	12 yd	1 Qt	1 1/2 Gal	2 Qt	1(1 1/2")			1 Gal	1 Qt	2 Qt	1 Gal	2 Qt	2 Qt
SONERAI II Fuselage and Tail	15 yd	1 Qt	1 3/4 Gal	3 Qt	1(1 1/2")			1 1/2 Gal	1 1/2 Qt	3 Qt	1 1/2 Gal	3 Qt	3 Qt
VOLKSPLANE VP-1	19 yd 8 yd Lt	2 Qt	3 Gal	1 1/4 Gal	3(2"), 1(3")	1	1(1/4")	2 1/2 Gal	2 1/2 Qt	1 1/4 Gal	2 1/2 Gal	5 Qt	1 1/4 Gal
VOLKSPLANE VP-2	26 yd 10 yd Lt	2 Qt	4 Gal	1 1/2 Gal	5(2"), 1(3")	1	2(1/4")	3 1/4 Gal	3 1/4 Qt	1 1/2 Gal	3 1/4 Gal	6 1/2 Qt	1 1/2 Gal
WITTMAN TAILWIND	24 yd 12 yd Lt	2 Qt	4 Gal	1 1/2 Gal	1(1"), 1(2"), 1(3")	50'	1(3/8")	3 1/4 Gal	3 1/4 Qt	1 1/2 Gal	3 1/4 Gal	6 1/2 Qt	1 1/2 Gal

# STAR GLOSS COVERING MATERIAL ESTIMATES

Aircraft and Components	Linear yards of 72-inch C-101/102 fabric; Light for plywood surfaces is listed separately.	Star-Tak Fabric Cement	One Coat Plus Taping		Polyester Finishing Tape Rolls ("B" = Bias)	Rib Lacing Cord (See Note 1)	Reinforcing Tape (Width same as cap strip)	Two Cross Coats			Two Coats		
			Gray Sealer, Gal (Thin 3:1)	Gray Sealer Reducer, Gal				Silver Urethane Fabric Primer, Gal (Thin 3:1)	Silver Urethane Fabric Primer Catalyst, Qt (4:1)	Randolph G-4200 Thinner, Gal	Randolph Ranthane HS Polyurethane Finish, Gal (Thin 3:1) (See Note 2)	Randolph Ranthane Catalyst AU-CAT-2X1, Qt (2:1)	Randolph G-4200 Ranthane Thinner, Gal
<b>GLIDERS</b>													
ASK-13 Fuselage	8 yd	1 Qt	1 Gal	2 Qt	1(2")			3 Qt	1 1/2 Pt	2 Qt	3 Qt	3 Pt	2 Qt
BG-7 Fuselage & Tail Surfaces	14 yd	1 Qt	1 1/2 Gal	3 Qt	1(2")	50'	1(3/8")	1 1/4 Gal	1 1/4 Qt	3 Qt	1 1/4 Gal	2 1/2 Qt	3 Qt
BG-12	31 yd	2 Qt	3 1/2 Gal	1 1/2 Gal	1(2")			2 3/4 Gal	2 3/4 Qt	1 1/2 Gal	2 3/4 Gal	5 1/2 Qt	1 1/2 Gal
CHEROKEE II	50 yd	3 Qt	5 1/2 Gal	2 1/4 Gal	3(1")			4 1/2 Gal	4 1/2 Qt	2 1/4 Gal	4 1/2 Gal	9 Qt	2 1/4 Gal
CHEROKEE II with R-M Wing	45 yd	3 Qt	5 Gal	2 Gal	3(2")			4 Gal	4 Qt	2 Gal	4 Gal	8 Qt	2 Gal
SCHWEIZER 2-12 (T6-3A)	30 yd	2 Qt	3 1/2 Gal	1 1/2 Gal	2(2"), 1(3")			2 3/4 Gal	2 3/4 Qt	1 1/2 Gal	2 3/4 Gal	5 1/2 Qt	1 1/4 Gal
SCHWEIZER 1-26A	24 yd	2 Qt	2 3/4 Gal	1 Gal	2(2"), 1(3")			2 1/4 Gal	2 1/4 Qt	1 1/4 Gal	2 1/4 Gal	4 1/2 Qt	1 1/4 Gal
SCHWEIZER 2-22	50 yd	1 Gal	5 1/2 Gal	2 1/4 Gal	7(2"), 1(3")		1(1/2")	4 1/2 Gal	4 1/2 Qt	2 1/4 Gal	4 1/2 Gal	9 Qt	2 1/4 Gal
FRANKLIN GLIDER	45 yd	1 Gal	5 Gal	2 Gal	3(2")			4 Gal	4 Qt	2 Gal	4 Gal	8 Qt	2 Gal
Ka 8b SAILPLANE	41 yd	2 Qt	4 1/2 Gal	2 Gal	1(1"), 5(2")	1	1(1/2")	3 3/4 Gal	3 3/4 Qt	2 Gal	3 3/4 Gal	7 1/2 Qt	2 Gal
WEIHE JS SAILPLANE	41 yd	2 Qt	4 1/2 Gal	2 Gal	1(1"), 5(2")	1	1(1/2")	3 3/4 Gal	3 3/4 Qt	2 Gal	3 3/4 Gal	7 1/2 Qt	2 Gal
<b>MISCELLANEOUS COVERING SUPPLIES</b>													
Anti-Chafe Cloth Tape													
Brushes													
Drain Grommets													
Seaplane Grommets													
Rib Screws & Alum. Washers													
Inspection Hole Reinforcing Rings													
Inspection Hole Covers													
Rib Lacing Needles													
Curved Needles													





Copyright © 2010  
Consolidated Aircraft Coatings  
Ceconite Division  
PO Box 3129  
Riverside, CA 92519-3129  
800-362-3490